

Model 350B

Temperature Controllers

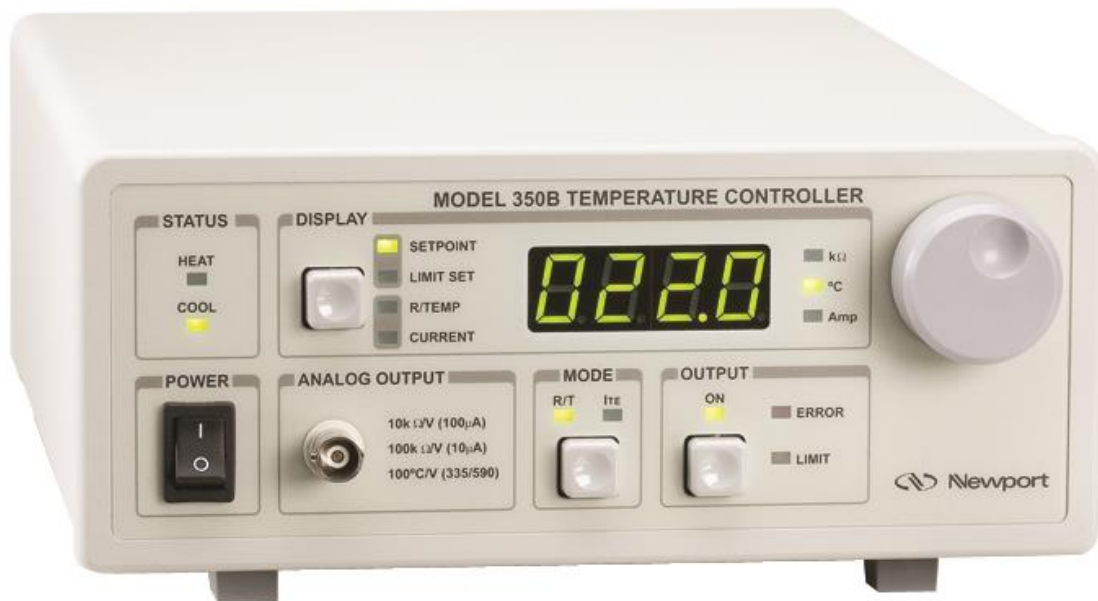

User's Manual



Newport®
Experience | Solutions

EU Declaration of Conformity

We declare that the accompanying product, identified with the **CE** mark, complies with requirements of the Electromagnetic Compatibility Directive, 2001/108/EC and the Low Voltage Directive 2006/95/EC.

Model Number: Model 350B Series Temperature Controllers

Year **CE** mark affixed: 2004

Type of Equipment: Electrical equipment for measurement, control and laboratory use

Standards Applied:

Compliance was demonstrated to the following standards to the extent applicable:

BS EN61326-1: 2006 “Electrical equipment for measurement, control and laboratory use – EMC requirements”

IEC 61010-1:2010 “Safety requirements for electrical equipment for measurement, control and laboratory use”



Todd McFarland
Senior Electrical Engineer
31950 E Frontage Rd
Bozeman, MT, USA

Warranty

Newport Corporation warrants that this product will be free from defects in material and workmanship and will comply with Newport's published specifications at the time of sale for a period of one year from date of shipment. If found to be defective during the warranty period, the product will either be repaired or replaced at Newport's option.

To exercise this warranty, write or call a local Newport office or representative, or contact Newport headquarters in Irvine, California. Prompt assistance and return instructions will be given. Send the product, freight prepaid, to the indicated service facility. Repairs will be made and the instrument returned freight prepaid. Repaired products are warranted for the remainder of the original warranty period or 90 days, whichever first occurs.

Limitation of Warranty

The above warranties do not apply to products which have been repaired or modified without Newport's written approval, or products subjected to unusual physical, thermal or electrical stress, improper installation, misuse, abuse, accident or negligence in use, storage, transportation or handling. This warranty also does not apply to fuses, batteries, or damage from battery leakage.

THIS WARRANTY IS IN LIEU OF ALL OTHER WARRANTIES, EXPRESSED OR IMPLIED, INCLUDING ANY IMPLIED WARRANTY OF MERCHANTABILITY OR FITNESS FOR A PARTICULAR USE. NEWPORT CORPORATION SHALL NOT BE LIABLE FOR ANY INDIRECT, SPECIAL, OR CONSEQUENTIAL DAMAGES RESULTING FROM THE PURCHASE OR USE OF ITS PRODUCTS.

First printing 2004

© 2004 by Newport Corporation, Irvine, CA. All rights reserved. No part of this manual may be reproduced or copied without the prior written approval of Newport Corporation.

This manual has been provided for information only and product specifications are subject to change without notice. Any change will be reflected in future printings.

Newport Corporation
1791 Deere Avenue
Irvine, CA, 92606
USA
Part No. 90036887 RevC May 2016

Confidentiality & Proprietary Rights

Reservation of Title:

The Newport programs and all materials furnished or produced in connection with them ("Related Materials") contain trade secrets of Newport and are for use only in the manner expressly permitted. Newport claims and reserves all rights and benefits afforded under law in the Programs provided by Newport Corporation.

Newport shall retain full ownership of Intellectual Property Rights in and to all development, process, align or assembly technologies developed and other derivative work that may be developed by Newport. Customer shall not challenge, or cause any third party to challenge the rights of Newport.

Preservation of Secrecy and Confidentiality and Restrictions to Access:

Customer shall protect the Newport Programs and Related Materials as trade secrets of Newport, and shall devote its best efforts to ensure that all its personnel protect the Newport Programs as trade secrets of Newport Corporation. Customer shall not at any time disclose Newport's trade secrets to any other person, firm, organization, or employee that does not need (consistent with Customer's right of use hereunder) to obtain access to the Newport Programs and Related Materials. These restrictions shall not apply to information (1) generally known to the public or obtainable from public sources; (2) readily apparent from the keyboard operations, visual display, or output reports of the Programs; 3) previously in the possession of Customer or subsequently developed or acquired without reliance on the Newport Programs; or (4) approved by Newport for release without restriction.

Trademarks

The Newport logo is a registered trademark of Newport Corporation in Austria, Barbados, Benelux, Canada, the People's Republic of China, Denmark, France, Germany, Great Britain, Ireland, Japan, the Republic of Korea, Spain, Sweden, and the United State. Newport is a registered trademark of Newport Corporation in Austria, Barbados, Benelux, the People's Republic of China, Denmark, France, Germany, Ireland, Japan, the Republic of Korea, Spain, and Sweden.

Service Information

This section contains information regarding factory service for the source. The user should not attempt any maintenance or service of the system or optional equipment beyond the procedures outlined in this manual. Any problem that cannot be resolved should be referred to Newport Corporation.

Technical Support Contacts

North America & Asia

Newport Corporation Service Dept.

1791 Deere Ave. Irvine, CA 92606

Telephone: (949) 253-1694

Telephone: (800) 222-6440 x31694

Europe

Newport/MICRO-CONTROLE S.A.

Zone Industrielle

45340 Beaune la Rolande, FRANCE

Telephone: (33) 02 38 40 51 56

Asia

Newport Opto-Electronics Technologies

253 Aidu Road, Bld #3, Flr 3, Sec C,
Shanghai 200131, China

Telephone: +86-21-5046 2300

Fax: +86-21-5046 2323

Newport Corporation Calling Procedure

If there are any defects in material or workmanship or a failure to meet specifications, promptly notify Newport's Returns Department by calling 1-800-222-6440 or by visiting our website at www.newport.com/returns within the warranty period to obtain a **Return Material Authorization Number (RMA#)**. Return the product to Newport Corporation, freight prepaid, clearly marked with the RMA# and the unit will either be repaired or replaced at our discretion. Newport is not responsible for damage occurring in transit and is not obligated to accept products returned without an RMA#.

E-mail: rma.service@newport.com

When calling Newport Corporation, please provide the customer care representative with the following information:

- Contact Information
- Serial number or original order number
- Description of problem (i.e., hardware or software)

To help our Technical Support Representatives diagnose the problem, please note the following conditions:

- Is the system used for manufacturing or research and development?
- What was the state of the system right before the problem?
- Have this problem been seen before? If so, how often?
- Can the system continue to operate with this problem? Or is the system non-operational?
- Can any differences be identified from before this problem occurred?

This page is intentionally left blank

Table of Contents

EU Declaration of Conformity	ii
Warranty	iii
Technical Support Contacts.....	v
Table of Contents	vii
List of Figures and Tables	ix

1 Safety Precautions 11

1.1	Definitions and Symbols.....	11
1.1.1	European Union CE Mark	11
1.1.2	Alternating voltage symbol	11
1.1.3	On	11
1.1.4	Off	12
1.1.5	Fuses.....	12
1.1.6	Frame or Chassis	12
1.1.7	Protective Conductor Terminal.....	13
1.2	Warnings and Cautions.....	13
1.2.1	General Warnings.....	13
1.2.2	General Cautions.....	14
1.2.3	Summary of Warnings and Cautions.....	15
1.3	Location of Warnings	16
1.3.1	Rear Panel.....	16

2 General Information 17

2.1	Introduction	17
2.2	Accessories.....	20

3 Getting Started 21

3.1	Unpacking and Handling	21
3.2	Inspection for Damage	21
3.3	Available Options and Accessories	21
3.4	Parts List	22
3.5	Choosing and Preparing a Suitable Work Area.....	22
3.6	Electrical Requirements	22
3.7	Power Supplies	23

4 System Operation 25

4.1	Front Panel	25
4.1.1	AC Power Switch.....	25

4.1.2	Analog Output.....	25
4.1.3	Mode Switch	26
4.1.4	Output Section	26
4.1.5	Status	26
4.1.6	Display	26
4.1.7	Control Knob.....	27
4.2	Rear Panel	28
4.2.1	USB Interface	28
4.2.2	Sensor Select Switch.....	28
4.2.3	TE Driver Output Connector	28
4.2.4	AC Power Inlet.....	29
4.2.5	Frame or Chassis Terminal	29
4.2.6	Power Inlet Socket.....	29

5 Computer Interfacing **31**

5.1	Memory	31
5.2	Commands and Queries	31

6 Software Application **46**

6.1	Overview	46
6.2	Connection	46
6.3	General Usage	47
6.3.1	LDD Tab	47
6.3.2	TEC Tab	48
6.4	Menu Structure.....	48

7 Principles of Operation **49**

7.1	Introduction	49
7.2	Thermistor	49
7.2.1	The Steinhart-Hart Equation.....	50
7.2.2	Table of Constants	51
7.3	Using Thermo-Electric Modules	52
7.4	Mounting Considerations	53
7.5	PID Tuning	55
7.5.1	PID Control Loop	55
7.5.2	P Loop	56
7.5.3	PI Loop	57
7.5.4	PID Loop	57
7.6	Model 350B Setup.....	58
7.6.1	Model 350B Operating Checklist.....	58

8	<i>Maintenance and Service</i>	61
8.1	Enclosure Cleaning	61
8.2	Fuse Replacement	61
8.3	Obtaining Service	62
8.4	Service Form	63

List of Figures

Figure 1	CE Mark	11
Figure 2	Alternating Voltage Symbol	11
Figure 3	On Symbol	11
Figure 4	Off Symbol	12
Figure 5	Fuse Symbol	12
Figure 6	Frame or Chassis Terminal Symbol	12
Figure 7	Protective Conductor Terminal	13
Figure 8	AC Receptacle Warning Label	14
Figure 9	Locations of warnings on the rear panel	16
Figure 10	WEEE Directive Symbol	16
Figure 11	Front Panel Layout (325B shown)	25
Figure 12	Rear Panel	28
Figure 13	Application front panel (TEC Tab)	46
Figure 14	Application front panel when communicating (LDD Tab)	47
Figure 15	Thermistor Resistance versus Temperature	51
Figure 16	TE Module Configuration	53
Figure 17	Mounting arrangement of a TE module, heat sink and laser diode	54
Figure 18	Basic block diagram of a temperature control system	55
Figure 19	Proportional Temperature Controller Block Diagram	56
Figure 20	PI Temperature Controller Block Diagram	57
Figure 21	PID Temperature Controller Block Diagram	57
Figure 22	Fuse Replacement	61

List of Tables

Table 1	Specifications Tables	19
Table 2	Command Summary	33
Table 3	Comparison of Curve Fitting Equations	51
Table 4	Thermistor Constants	52

This page is intentionally left blank

1 Safety Precautions

1.1 Definitions and Symbols

The following terms and symbols are used in this documentation and also appear on the Model 350B Temperature Controllers where safety-related issues occur.

1.1.1 European Union CE Mark



Figure 1

CE Mark

The presence of the CE Mark on Newport Corporation equipment means that it has been designed, tested and certified as complying with all applicable European Union (CE) regulations and recommendations.

1.1.2 Alternating voltage symbol



Figure 2 Alternating Voltage Symbol

This international symbol implies an alternating voltage or current.

1.1.3 On



Figure 3 On Symbol

The On Symbol in the figure above represents a power switch position on the Model 350B Temperature Controllers. This symbol represents a Power On condition.

1.1.4 Off

Figure 4 Off Symbol

The Off Symbol in the figure above represents a power switch position on the Model 350B Temperature Controllers. This symbol represents a Power Off condition.

1.1.5 Fuses

Figure 5 Fuse Symbol

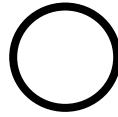
The fuse symbol in the figure above identifies the fuse location on the Model 350B Temperature Controllers.

1.1.6 Frame or Chassis

Figure 6 Frame or Chassis Terminal Symbol

This symbol identifies the frame or chassis terminal.

1.1.7 Protective Conductor Terminal

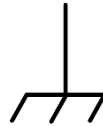

Figure 7 Protective Conductor Terminal

The protective conductor terminal symbol in the above figure identifies the location of the bonding terminal, which is bonded to conductive accessible parts of the enclosure for safety purposes. The intent is to connect it to an external protective earthing system through the power cord.

1.2 Warnings and Cautions

The following are definitions of the Warnings, Cautions and Notes that are used throughout this manual to call attention to important information regarding user safety, the safety and preservation of equipment or an important tip.

WARNING

Situation has the potential to cause bodily harm or death.

CAUTION

Situation has the potential to cause damage to property or equipment.

NOTE

Additional information the user or operator should consider.

1.2.1 General Warnings

Observe these general warnings when operating or servicing this equipment:

- Heed all warnings on the unit and in the operating instructions.
- Do not use this equipment in or near water.
- This equipment is grounded through the grounding conductor of the power cord.
- Route power cords and other cables so they are not likely to be damaged.
- Disconnect power before cleaning the equipment. Do not use liquid or aerosol cleaners; use only a damp lint-free cloth.
- Lockout all electrical power sources before servicing the equipment.
- To avoid fire hazard, use only the specified fuse(s) with the correct type number, voltage and current ratings as referenced in the appropriate locations in the service instructions or on the equipment. Only qualified service personnel should replace fuses.

- To avoid explosion, do not operate this equipment in an explosive atmosphere.
- Qualified service personnel should perform safety checks after any service.

1.2.2 General Cautions

Observe these cautions when operating or servicing this equipment:

- Before applying power, carefully read the warning label placed over the AC power input receptacle in back of the instrument.

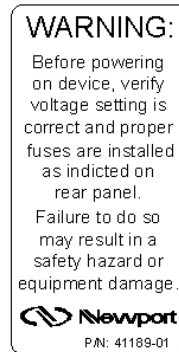

Figure 8 AC Receptacle Warning Label

- If this equipment is used in a manner not specified in this manual, the protection provided by this equipment may be impaired.
- To prevent damage to equipment when replacing fuses, locate and correct the problem that caused the fuse to blow before re-applying power.
- Do not block ventilation openings.
- Use only the specified replacement parts.
- Follow precautions for static sensitive devices when handling this equipment.
- This product should only be powered as described in the manual.
- There are no user-serviceable parts inside the Model 350B Temperature Controllers.
- To prevent damage to the equipment, read the instructions in the equipment manual for proper input voltage.
- Damage may occur if Voltage Select tumbler is turned without removing from the Input Power cord.

1.2.3 Summary of Warnings and Cautions

The following general warning and cautions are applicable to this instrument:

WARNING

Before operating the Model 350B Temperature Controllers, please read and understand all of Section 1.

WARNING

Do not attempt to operate this equipment if there is evidence of shipping damage or there is reason to suspect the unit is damaged. Damaged equipment may present additional hazards to the user. Contact Newport technical support for advice before attempting to plug in and operate damaged equipment.

WARNING

To avoid electric shock, connect the instrument to properly earth-grounded, 3-prong receptacles only. Failure to observe this precaution can result in severe injury.

WARNING

To reduce the risk of electric shock or damage to the instrument, turn the power switch off and disconnect the power cord before replacing a fuse.

WARNING

Before cleaning the enclosure of the Model 350B Temperature Controllers, the AC power cord must be disconnected from the wall socket.

CAUTION

Make sure that the selector is set at the position that corresponds to the mains voltage. Follow directions in section 4.2.4 to properly set tumbler.

CAUTION

There are no user serviceable parts inside the Model 350B Temperature Controllers. Work performed by persons not authorized by Newport Corporation will void the warranty. For instructions on obtaining warranty repair or service, please refer to Section 8.

CAUTION

All units are factory preset to operate at 108-132VAC, 60Hz.

1.3 Location of Warnings

1.3.1 Rear Panel

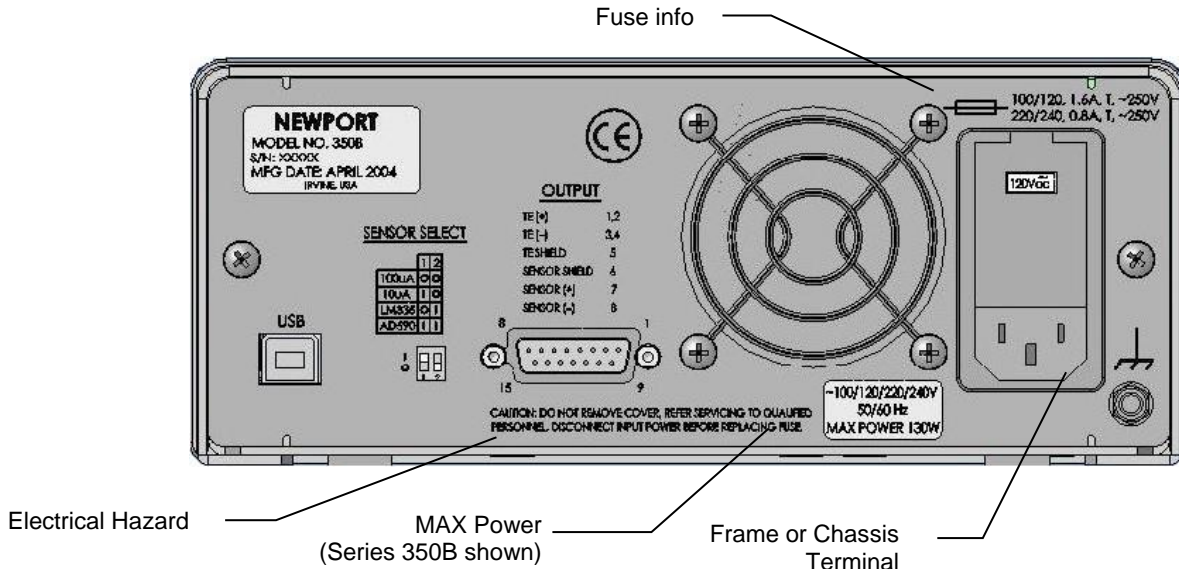

Figure 9 Locations of warnings on the rear panel

NOTE

The Model 350B Temperature Controller is intended for use in an industrial laboratory environment. Use of these products in other environments, such as residential, may result in electromagnetic compatibility difficulties due to conducted as well as radiated disturbances.

Waste Electrical and Electronic Equipment (WEEE)



Figure 10

WEEE Directive Symbol

This symbol on the product or on its packaging indicated that this product must not be disposed of with regular waste. Instead, it is the user responsibility to dispose of waste equipment according to the local laws. The separate collection and recycling of the waste equipment at the time of disposal will help to conserve natural resources and ensure that it is recycled in a manner that protects human health and the environment. For information about where the user can drop off the waste equipment for recycling, please contact a local Newport Corporation representative.

2 General Information

2.1 Introduction

The intended use of the 350B Temperature Controllers is to precisely control the temperature of a thermo-electric (TE) cooler in a closed loop system using a variety of possible temperature sensors as the feedback. They offer a combination of features, performance, and value that is unmatched by other laser diode temperature controllers.

Three operating modes are user selectable: constant R (thermistor), constant T (thermistors), or constant I_{TE} (TE cooler), while delivering output power up to 55 Watts.

Quiet, safe and stable output current results from a P-I-D control circuitry with complete flexibility for adjustment through the Newport LDD/TEC Application software (included) or user developed programs. The PID control algorithm is implemented to achieve optimal stability and settling performance along with an I_{TE} current limit setting to protect TE coolers from damage, regardless of operating mode.

The P-I-D control loop renders performance for fast settling onto a low noise, bipolar current output in three operating modes: 1) constant thermistor resistance, 2) constant Temperature as monitored by a thermistor, or 3) constant peltier-cooler (thermo-electric) temperature. A user adjustable TE-cooler current limit setting unconditionally protects the TE modules from damage by excessive drive current independent of the operating mode. The Model 350B temperature controller is compatible with thermistors.

Temperature readings are displayed in °C as an option when using thermistors. A USB interface is standard feature in all models, permitting interfacing to a PC to control from Newport's LDD/TEC Application software or user's developed application using the included LabVIEW drivers.

Additional Benefits

1. Preset display allows adjustable operating setpoint before switching the output on.
2. Low noise, bipolar current output.
3. Wide TEC temperature range from -50 to +150°C.
4. Analog interface provides remote control capability.

Specifications

		Model 350B
Output		
Type	Bipolar, constant current source	
TEC Control Loop Type	Hybrid P-I-D	
Maximum Current (A)	±5	
Compliance Voltage (V)	11	
Available Output Power (W)	55	
Accuracy (mA)	±9	
Resolution (mA)	0.084	
Ripple/Noise (mA rms)	<0.03	
Current Limit		
Range (A)	0–5.05	
Accuracy (mA)	±9	
Resolution (mA)	0.084	
Stability		
Short-Term Stability (1 h)	0.001°C	
Long-Term Stability (24 h)	0.005°C	
Display		
Range		
Temperature (°C)	-50.0 to +150.0°C	
Resistance (10 µA) (kΩ)	0.1–200.0	
Resistance (100 µA) (kΩ)	0.01–20.00	
TE Current (A)	-5.00 to +5.00	
Resolution		
Temperature	0.1°C	
Resistance (10 µA) (Ω)	100	
Resistance (100 µA) (Ω)	10	
TE Current (mA)	10	
Accuracy		
Temperature	±0.1°C	
Resistance (10 µA)	±100Ω	
Resistance (100 µA)	±10Ω	
TE Current (mA)	±10	

Temperature Sensors	
Sensor Type	Thermistor NTC 2-wire
Temperature Control Resolution	0.01°C
Temp. Sensor Control Accuracy (at 25°C)	±0.2°C
Sensor Bias	10/100 µA

Overall Specifications

Voltage Requirements	~100/120/220/240 VAC +/-10%, 50–60Hz
Power Requirements	325B MAX POWER = 60W 350B MAX POWER = 130W
Chassis Ground	4 mm banana jack
Size (H x W x D) [in. (mm)]	3.5 (88) x 8.5 (215) x 12.6 (320)
Weight [lb (kg)]	8.9 (4.05)
Operating Temperature	0°C to 40°C (<90% humidity non-condensing)
Operating Altitude	3000 m (10,000 feet)
Storage Temperature	-29°C to + 60°C
Storage Relative Humidity	<85% humidity non-condensing
Safe Use Environment	Indoor
Electrical Class	1
Pollution Degree	2
Transient Overvoltage Category	2
Connectors	
Output Connectors TE Module and Sensor	15-pin female D-sub
Analog Output	BNC
USB Connector	Type B

Table 1 *Specifications Tables*

2.2 Accessories

The Model 350B Temperature Controller come with a line cord for connection to AC power. To order accessories use the following part numbers:

Model	Description
300-02	Temperature Controller Cable
300-04	TEC/Mount Cable
300-16	10.0 k Ω Thermistor ($\pm 0.2^{\circ}\text{C}$)

3 Getting Started

3.1 Unpacking and Handling

It is recommended that the Model 350B Temperature Controller be unpacked in a lab environment or work site. Unpack the system carefully; small parts and cables are included with the instrument. Inspect the box carefully for loose parts before disposing of the packaging. The user is urged to save the packaging material in case the need to ship the equipment arises in the future.

3.2 Inspection for Damage

The Model 350B Temperature Controller are carefully packaged at the factory to minimize the possibility of damage during shipping. Inspect the box for external signs of damage or mishandling. Inspect the contents for damage. If there is visible damage to the instrument upon receipt, inform the shipping company and Newport Corporation immediately.

WARNING

Do not attempt to operate this equipment if there is evidence of shipping damage or there is reason to suspect the unit is damaged. Damaged equipment may present additional hazards to the user. Contact Newport technical support for advice before attempting to plug in and operate damaged equipment.

3.3 Available Options and Accessories

Accessories:

300-02	Temperature Controller Cable
300-04	TEC/Mount Cable
300-16	10.0 k Ω Thermistor ($\pm 0.2^{\circ}\text{C}$)

Newport Corporation also supplies temperature controlled mounts, lenses, and other accessories. Please consult with a representative for additional information.

3.4 **Parts List**

The following is a list of parts included with the Model 350B Temperature Controller:

1. User's manual (CD) and a Printed Copy
2. Power cord
3. Temperature Controller
4. Fuses (2 pieces)
5. Certificate of Calibration

If any hardware is missing or there are any questions about the hardware received, please contact Newport Corporation.

3.5 **Choosing and Preparing a Suitable Work Area**

The Model 350B Temperature Controller may be placed on any reasonably firm table or bench during operation. The front legs of the unit can be pulled out to tilt the unit at an angle, if desired.

Provide adequate distance between the Model 350B Temperature Controller and adjacent walls for ventilation purposes. Approximately 2-inch spacing for all surfaces is adequate.

CAUTION

The primary means for disconnection from the AC mains is disconnecting the power cord from the instrument. Do not position this instrument that makes it difficult to disconnect the power cord.

3.6 **Electrical Requirements**

Before attempting to power up the unit for the first time, the following precautions must be followed:

WARNING

To avoid electric shock, connect the instrument to properly earth-grounded, 3-prong receptacles only. Failure to observe this precaution can result in severe injury.

- Have a qualified electrician verify the wall socket that will be used is properly polarized and properly grounded.
- Set the mains selector tumbler to the voltage that matches the power outlet AC voltage. Follow directions in section 4.2.4 to properly set tumbler.

3.7 Power Supplies

AC power is supplied through the rear panel input power connector that provides in-line transient protection and RF filtering. The input power connector contains the fuses and the switch to select series or parallel connection of the transformer primaries for operation at 100VAC, 120VAC, 220VAC or 240VAC. Refer to paragraph 4.2.4 before applying power.

This page is intentionally left blank

4 System Operation

WARNING

Before operating the Model 350B Temperature Controller, please read and understand all of Section 1.

4.1 Front Panel

The front panel of the Model 350B Temperature Controller is arranged for easy operation. Six distinct areas, each with a specific set of related functions, and a control knob are located on the front panel, as shown in Figure 11 below.

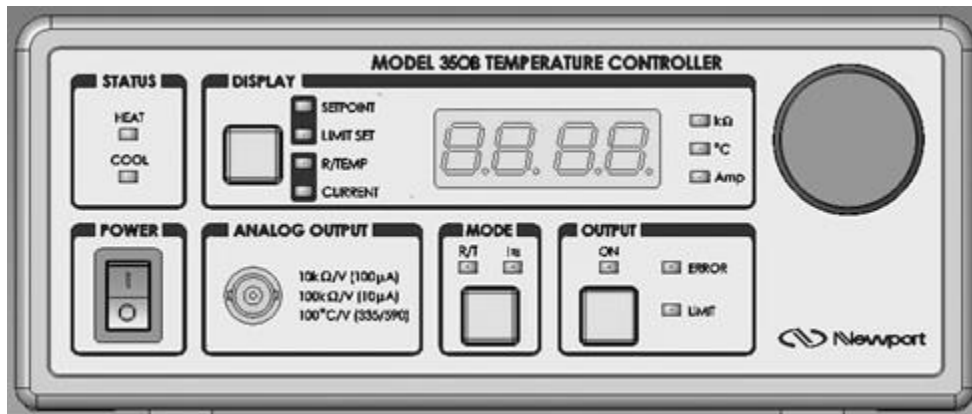

Figure 11 Front Panel Layout (350B shown)

4.1.1 AC Power Switch

When the AC power is turned on the unit starts up with the OUTPUT off, display in SETPOINT mode, and mode of operation in either R/T or ITE mode depending upon the mode selected when the unit was last turned OFF.

4.1.2 Analog Output

A BNC connector can be used to monitor the temperature sensor value. The transfer function of the output is dependent on the sensor type selected. The thermistor current selection values are either 10μA or 100μA and result in either 100 kΩ/V or 10 kΩ/V respectively.

Analog Output Level, VDC (BNC Connector)

R/T or I_{TE} MODE

Range	Output Voltage Level	Corresponding R/T Value
100 μ A	0 to 2V	0 to 20 k Ω
10 μ A	0 to 2V	0 to 200 k Ω

4.1.3 Mode Switch

The Model 350B can be operated in either 1) constant R (thermistor resistance), 2) constant T (thermistor), or 3) constant I_{TE} mode. The R/T mode is used with temperature sensors and the I_{TE} mode to maintain a constant output current. If constant T mode is selected and the sensor type is a thermistor, all temperature to resistance conversions are done using the Steinhart-Hart equation. Please refer to “TEC:CONST” command to modify the sensor constants.

4.1.4 Output Section

Output ON Switch

Pushing this switch allows current flow to the TE module. The output stays on, as indicated by the green LED above, until the switch is pushed again or an error condition occurs.

Error Indicator LED

An ERROR condition occurs when there is an open circuit to the TE module or temperature sensing device. The output current is automatically turned off. Once the device is replaced or reconnected, pushing the output switch twice will clear the error indication and restore the output on condition.

Limiting Indicator LED

This LED lights up whenever the output current reaches a user adjustable threshold, limiting the current flow to the TE module. It usually occurs during initial startup as the drive circuitry attempts to reach equilibrium.

4.1.5 Status

The STATUS indicator LEDs show whether the device under temperature control is being heated or cooled.

4.1.6 Display

A 3 1/2 digit green LED display is located in the top center of the front panel. It reads in k Ω when displaying a thermistor resistance value, $^{\circ}$ C when displaying a temperature equivalent to a thermistor resistance value, or Amps when in the constant current I_{TE} mode. Pushing the switch cycles through the display values as described below. Display modes can be toggled with the output on or off.

SETPOINT Display

The SETPOINT display mode is used to set the appropriate output value using the rotary control knob before turning the OUTPUT on. Once the control level is set, the OUTPUT may be turned on and the actual SENSOR or CURRENT value can be monitored.

LIMIT SET Display

This mode allows setting output current limit level with the control knob.

R/TEMP Display

The actual temperature sensor value is monitored in this mode. The value displayed depends on the sensor being used and the mode of operation.

See table below for details.

	R MODE	T MODE	I_{TE} MODE
Thermistor	k Ω	$^{\circ}$ C	$^{\circ}$ C

CURRENT Display

This readout monitors the actual current level in Amps being supplied to the TE module. When the OUTPUT is first selected this current value may be as high as the LIMIT value. As the temperature stabilizes the output current will decrease.

Indicator LEDs

To the right of the numeric display are three LEDs which indicate measurement units: 1) resistance in k Ω , 2) temperature in $^{\circ}$ C, or 3) output current in Amps.

4.1.7**Control Knob**

The knob control on the right side of the front panel sets the appropriate reference value corresponding to either resistance (thermistor), temperature (thermistor), or TE current (I_{TE}) to be maintained by the Model 350B Temperature Controller.

4.2 Rear Panel

Figure 12 shows the layout of the rear panel that contains OUTPUT and USB connectors, the sensor select switch, and the AC power inlet.

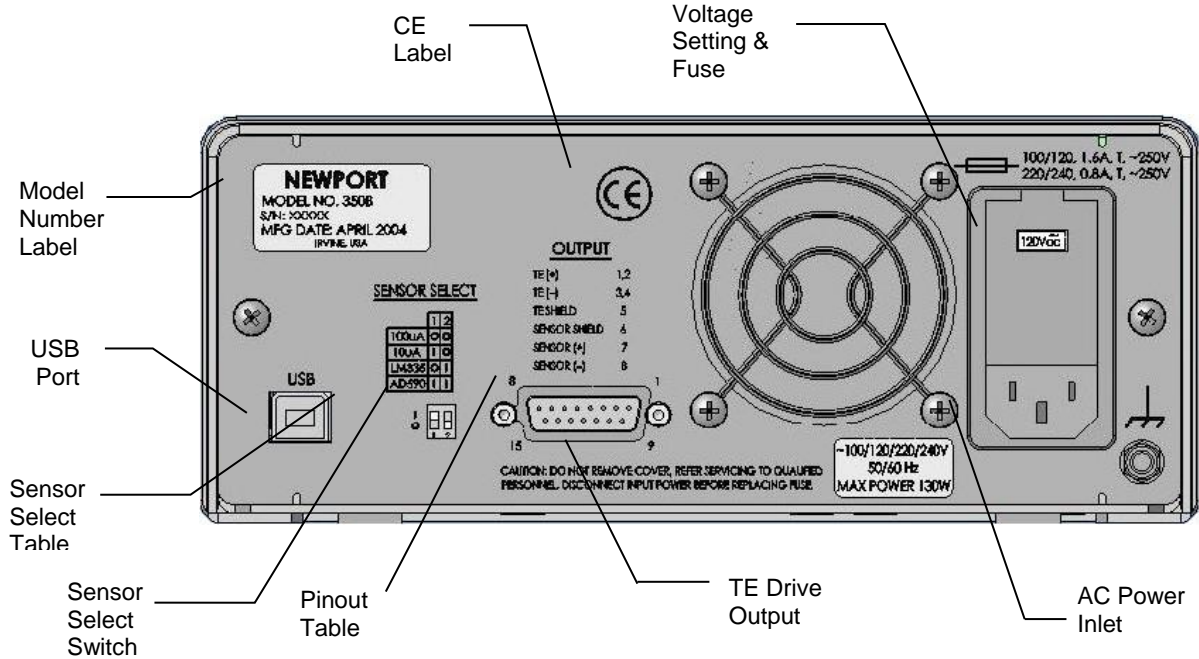

Figure 12 Rear Panel

4.2.1 USB Interface

The instrument is designed to communicate with standard USB interfaces. The cable required is a USB A/ B connection cable.

4.2.2 Sensor Select Switch

This dual-position DIP switch is used to select the appropriate bias for each one of the sensor types. The switch position for each sensor is printed on the rear panel next to the switch. The LM335 and AD590 sensor positions do not operate at this time.

4.2.3 TE Driver Output Connector

Connections to the TE module and temperature sensor are made using a 15-pin, D-sub connector respectively. There are two pins each for the TE+ and TE- Connections to provide redundancy and reduce the voltage drop in the cable.

Pin #	Connection	Wire Color (300-02 cable)
1 & 2	TE +	RED
3 & 4	TE -	BLACK
5	TE SHIELD	
6	SENSOR SHIELD	
7	SENSOR +	GREEN
8	SENSOR -	WHITE

4.2.4 AC Power Inlet

The input voltage setting is indicated in a small window on the face of the power module. A small screwdriver is needed to flip down the panel once the AC line cord is removed. Carefully remove plastic tumbler and reinsert it to show the appropriate power grid voltage. The fuse is also located behind this panel and can be pulled out, for replacement with the appropriate size, as indicated on the back panel.

All units are preset at the factory for operation at 108-132VAC, 60HZ.

The fuse must be changed for 198-242VAC and 216-264VAC operation.

Select:

- 100VAC for operation at 90-110VAC, 60Hz
- 120VAC for operation at 108-132VAC, 60Hz
- 220VAC for operation at 198-242VAC, 50Hz
- 240VAC for operation at 216-264VAC, 50Hz

The line cord supplied with each unit should be plugged only into a properly grounded three-prong outlet to prevent electrical shock in the event of an internal short circuit to the metal cabinet.

4.2.5 Frame or Chassis Terminal

This terminal provides the means to connect to the enclosure.

4.2.6 Power Inlet Socket

Plug the included power cord into the Power Inlet Socket on the rear of the instrument, then plug the power cord into a wall socket with proper earth grounding.

This page is intentionally left blank

5 Computer Interfacing

5.1 Memory

The calibration constants and other temperature controller parameters that must be retained even when the power is removed from the unit are stored in an electrically erasable programmable memory (EEPROM).

5.2 Commands and Queries

There are two types of device commands: commands that cause the instrument to take a desired action, and queries that return a stored value or state of the instrument. Queries must end with a question mark (?), while commands may require parameter(s) to follow:

TEC:LIMit:I 2.00

For example, the value “2.00” in the command **TEC:LIMit:I 2.00**, sets the output current limit at 2.00. Table 2 below summarizes all the commands and queries supported by the instrument. The command/query **MUST** contain all of the letters which are shown in upper case in this table. The lower case letters shown with the commands are optional, and may be used for clarity.

The commands may be sent to the instrument in either upper or lower case or in any combination. For example, the following commands are equivalent:

TEC:LIMit:I 2.00

TEC:LIM:I 2.00

tec:LIM:I 2.00

TeC:Lim:I 2.00

COMMAND EXECUTION:

The controller interprets the commands in the order they are received and execute them sequentially. If a set of commands have to be executed closer to each other, these commands can be sent to the controller simultaneously by creating a command string with semicolon (;) used as a command separator. The command string length should not exceed 50 characters. In the example shown below, a command string was created with semicolon separating 5 queries. The controller responds to this command string with a response that has 5 values using a comma (,) as a separator.

COMMAND STRING:

TEC:OUT?;TEC:SET:I?;TEC:I?;TEC:SET:R?;ERR?

INSTRUMENT RESPONSE:

0,1.25,0.00,10.00,0

COMMAND TERMINATION:

All commands sent to the instrument must be terminated by <Carriage Return><Line Feed>.characters. All responses sent out by the instrument are terminated by the same characters.

Commands common to both Temperature Controllers and Laser Diode Drivers:

Command Syntax	Command Description	Remarks
*CLS	Clear status and response buffer command	
*IDN?	Identification Query	
*RCL	Recall Settings	Restore instrument to setup state stored in its non-volatile local memory
*RST	Reset Instrument	
*SAV	Save Settings	Save instrument's current settings in its non-volatile local memory
*STB?	Status Byte Query	Returns "message available" and "error message available" status and "output out of tolerance" status
ADDRess	Address Command	Sets the controller USB address
ADDRess?	Address Query	Returns the controller's USB address
ERRors?	Error query	Returns error code
ERRSTR?	Error string query	Returns error string
HWTemp?	Temperature query	Returns instrument temperature in deg. C
LOCAL	Return to local mode	Makes front panel buttons active

Commands specific to Temperature Controllers:

Command Syntax	Command Description	Remarks
TEC:CONST	TEC sensor constants command	
TEC:CONST?	TEC sensor constants query	
TEC:GAIN:PID	TEC PID settings	
TEC:GAIN:PID?	TEC PID settings query	
TEC:Ite	TEC I_{TE} set point	
TEC:Ite?	TEC measured I_{TE} query	
TEC:LIMit:Ite	TEC I_{TE} current limit set	
TEC:LIMit:Ite?	TEC I_{TE} current limit set query	
TEC:MODE:Ite	I_{TE} mode	
TEC:MODE:R	Resistance mode	Valid if sensor is thermistor
TEC:MODE:T	Temperature mode	Valid for thermistor
TEC:MODE?	TEC mode query	
TEC:OUTput	TEC output enable/disable	
TEC:OUTput?	TEC output enable status query	
TEC:R	TEC thermistor set point	Valid if sensor is thermistor
TEC:R?	TEC measured R query	Valid if sensor is thermistor
TEC:SENsor?	TEC sensor type setting query	
TEC:SET:Ite?	TEC I_{TE} set point query	
TEC:SET:R?	TEC thermistor set point query	Valid if sensor is thermistor
TEC:SET:T?	TEC temperature set point query	Valid for thermistor
TEC:T	TEC temperature set point	Valid for thermistor
TEC:T?	TEC measured temperature query	Valid for thermistor

Table 2 Command Summary

***CLS**

Description Clear status and response buffer command

Syntax *CLS

Remarks The *CLS command is used to clear the status byte register and the response buffer. This command may be issued if query commands and their responses fall out of sync with each other.

See Also *STB?

***IDN?**

Description Identification query.

Syntax *IDN?

Remarks This query will cause the instrument to return an identification string.

Model name	Firmware version #	Firmware date	Controller Serial #
XXXX	vYYY	mm/dd/yy	SN ZZZZ

NEWPORT XXXX vYYY mm/dd/yy, SN ZZZZ

Examples:

NEWPORT 350B v2.00 05/17/04,SN 1

***RCL**

Description Recall command.

Syntax *RCL value

Argument	Value	Description
<i>Value</i>	0	Restores Factory Default settings
	1	Restores last saved working setting
	2	Restores last saved user settings

Remarks The recall command restores the instrument to the setup state which was last saved using *SAV Command.

See Also *RST, *SAV

***RST**

Description Reset command.

Syntax *RST

Remarks The reset command performs a device reset.

See Also *RCL

SAV*Description** Save command.**Syntax** *SAV value

Argument	Value	Description
<i>Value</i>	0	Invalid
	1	Saves current settings to working settings
	2	Saves current settings to user settings

Remarks The save command stores the current state of the instrument in non-volatile local memory. This state is then recalled by using the *RCL recall command.**See Also** *RCL

STB?*Description** Status Byte Register query.**Syntax** *STB?**Remarks** The Read Status Back query allows the programmer to read the Status Byte Register.

Response	Description
<i>Status Byte Register</i>	bit 0 Reserved
	bit 1 Reserved
	bit 2 Reserved
	bit 3 Reserved
	bit 4 Message Available
	bit 5 Reserved
	bit 6 Reserved
	bit 7 Error Message Available

ADDRESS**Description** USB address command.**Syntax** ADDRESS value**Remarks** The ADDRESS command sets the instrument USB address. After changing USB address, the communication with the instrument has to be re-initialized. This can be accomplished by calling "InitSystem" function in the DLL available in the CD provided with the instrument.

Argument	Value	Description
<i>Value</i>	0	Reserved
	1 to 99	Valid USB address range

See Also ADDRESS?

ADDRess?

Description USB address query.

Syntax ADDRess?

Remarks The ADDRess query returns the controller's USB address.

Response	Value	Description
<i>address</i>	0	<i>Reserved</i>
	1 to 99	<i>Valid USB address range</i>

See Also ADDRess

ERRors?

Description Error query.

Syntax ERRors?

Remarks The ERRors? query returns a list of commands and device errors which have occurred since the last query. These errors are indicated by a number that corresponds to the type of error which occurred.

Response	Description
<i>Error code</i>	Error code number, 0 if no errors

See Also ERRSTR?

Error Messages

0 NO ERROR

No errors exist in the output buffer.

115 IDENTIFIER NOT VALID

The issued command does not exist. Check the command syntax.

200 REMOTE MODE

Instrument is presently in remote mode. As a result, the rotary knob, "MODE" and "OUTPUT" switches have been made inactive. Issue "LOCAL" command to make the knob and switches active.

201 VALUE OUT OF RANGE

The specified parameter is out of range. Refer to the description of issued command for valid parameter range.

402 SENSOR OPEN

Once the fault is corrected, "TEC:OUTput 1" command must be issued once to clear the error indication, and a second time to restore current to the TE module.

405 COMP VOLTAGE LIMIT ERROR

The output has been turned OFF because the forward voltage drop of a TE module exceeds the compliance voltage specified in the Specification table. Once the fault is corrected, “TEC:OUTput 1” command must be issued once to clear the error indication, and a second time to restore current to the TE module.

409 SENSOR CHANGE

The output has been turned OFF because a sensor change was done by modifying the sensor select switch setting. Sensor select switch is located in the rear panel of the instrument.

415 SENSOR CHANGE

Once the fault is corrected, “TEC:OUTput 1” command must be issued once to clear the error indication, and a second time to restore current to the TE module.

419 MODE CHANGE

The output has been turned OFF because a mode change was commanded using either “TEC:MODE:I” or “TEC:MODE:R” or “TEC:MODE:T” commands.

420 SENSOR MISMATCH

The command issued is not supported for the selected sensor type. This message is obtained when an IC sensor is selected, and resistance related commands are issued.

901 SYSTEM OVER TEMPERATURE ERROR

The output has been turned OFF because temperature inside the instrument has exceeded 75 degC. Once the fault is corrected, “TEC:OUTput 1” command must be issued once to clear the error indication, and a second time to restore current to the TE module.

ERRSTR?

Description Error string query.

Syntax **ERRSTR?**

Remarks The **ERRSTR?** query returns a list of commands and device error numbers along with the corresponding error text strings which have occurred since the last query.

Response	Description
<i>Error code, “text”</i>	Error code and text for error code as per chapter, 0 if no errors

See Also **ERRors?**

HWTemp?

Description Hardware (chassis) temperature query.

Syntax **HWTemp?**

Remarks The **HWTemp?** query returns the value of the hardware temperature measurement.

Response	Description
<i>measured temp</i>	Measured temperature in °C

This measurement is updated approximately once every 225 milliseconds.

LOCAL

Description Return to local mode (from USB remote)

Syntax **LOCAL**

Remarks Returns the controller to local mode after being placed in remote mode by the USB interface. The instrument will be set to Local Mode if no commands are sent to it via its USB interface for 10-seconds.

TEC:CONST

Description TEC sensor constants command.

Syntax **TEC:CONST C1, C2, C3**

Remarks The **TEC:CONST** command sets the TEC constants for the Steinhart-Hart equation for thermistors.

Argument	Description
<i>For thermistors</i>	
<i>C1</i>	$\pm 9.999 \times 10^{-3}$ Steinhart-Hart constants
<i>C2</i>	$\pm 9.999 \times 10^{-4}$
<i>C3</i>	$\pm 9.999 \times 10^{-7}$

See Also **TEC:CONST?**

TEC:CONST?

Description TEC sensor constants query.

Syntax **TEC:CONST?**

Remarks The **TEC:CONST?** query returns the TEC constants for the Steinhart-Hart equation for thermistors.

Response	Description
<i>C1</i>	See TEC:CONST for a description of these constants.
<i>C2</i>	
<i>C3</i>	

See Also **TEC:CONST**

TEC:GAIN:PID

Description TEC PID controller gain constants command.

Syntax **TEC:GAIN:PID Kp,Ki,Kd**

Remarks The **TEC:GAIN:PID** command sets the proportional, integral and derivative control gain constants.

Argument	Value	Description
Kp	1 to 1000	Proportional gain constant
Ki	1 to 1000	Integral gain constant
Kd	1 to 1000	Derivative gain constant

Examples TEC:GAIN:PID 50,2,20

Action: sets Kp to 50; Ki to 2; Kd to 20

See Also **TEC:GAIN:PID?**

TEC:GAIN:PID?

Description TEC PID controller gain constants query.

Syntax **TEC:GAIN:PID?**

Remarks The **TEC:GAIN:PID?** command returns the proportional, integral and derivative control gain constants.

Response	Description
Kp	Proportional gain constant
Ki	Integral gain constant
Kd	Derivative gain constant

See Also **TEC:GAIN:PID**

TEC:Ite

- Description** TEC I_{TE} set point command.
- Syntax** **TEC:Ite** *set point*
- Remarks** The **TEC:Ite** command sets the TEC control current set point.

Argument	Description
<i>set point</i>	set point in Amps

- See Also** **TEC:Ite?**, **TEC:LIMit:Ite**, **TEC:SET:Ite?**

TEC:Ite?

- Description** TEC measured I_{TE} query.
- Syntax** **TEC:Ite?**
- Remarks** The **TEC:Ite?** query returns the value of the measured TEC output current.

Response	Description
<i>measured output</i>	Current in Amps

The TEC current is constantly measured and updated, regardless of the TEC mode of operation.

This measurement is updated approximately once every 225 milliseconds.

- See Also** **TEC:Ite**

TEC:LIMit:Ite

- Description** TEC ITE current limit command
- Syntax** **TEC:LIMit:Ite** *limit*
- Remarks** The **TEC:LIMit:Ite** command sets the TEC ITE current limit value.

Argument	Description
<i>limit</i>	Limit in Amps

The factory default current limit is 50% of the maximum current.

- See Also** **TEC:Ite**

TEC:LIMit:Ite?

Description TEC ITE current limit query

Syntax **TEC:LIMit:Ite?**

Remarks The **TEC:LIMit:Ite?** query returns the value of the TEC current limit.

Response	Description
<i>limit</i>	Limit in Amps

See Also **TEC:LIMit:Ite**

TEC:MODE:Ite

Description TEC ITE mode command.

Syntax **TEC:MODE:Ite**

Remarks The **TEC:MODE:Ite** command selects TEC constant current mode.

Changing modes causes the output to be forced off, and the new mode's set point value will be displayed.

See Also **TEC:Ite, TEC:MODE?**

TEC:MODE:R

Description TEC R mode command.

Syntax **TEC:MODE:R**

Remarks The **TEC:MODE:R** command selects TEC constant thermistor resistance mode.

Since sensor resistance (or linear sensor reference) is a function of temperature, this mode also controls the TEC output temperature, but it bypasses the use of the conversion constants for set point calculation. This allows finer control of temperature in cases where the sensor's temperature model (and therefore the constants) is not known.

Changing modes causes the output to be forced off, and the new mode's set point value will be displayed.

See Also **TEC:MODE?, TEC:R**

TEC:MODE:T

Description TEC temperature mode command.

Syntax **TEC:MODE:T**

Remarks The **TEC:MODE:T** command selects TEC constant temperature mode.

Since TEC temperature is derived from thermistor or RTD resistance, constant R and T modes are related. In T mode the set point is converted to resistance by using the appropriate constants and conversion model.

Changing modes causes the output to be forced off, and the new mode's set point value will be displayed.

See Also **TEC:MODE?**, **TEC:T**

TEC:MODE?

Description TEC control mode query.

Syntax **TEC:MODE?**

Remarks The **TEC:MODE?** query returns the selected TEC control mode.

Response	Value	Description
<i>mode</i>	ITE	constant current
	R	constant R
	T	constant T

See Also **TEC:MODE:Ite**, **TEC:MODE:R**, **TEC:MODE:T**

TEC:OUTput

Description TEC output enable command.

Syntax **TEC:OUTput** *enable*

Remarks The **TEC:OUTput** command enables or disables the TEC output.

Argument	Value	Description
<i>enable</i>	0	off
	1	on

After the output is turned on, it may be useful to wait until the output is stable (within tolerance) before performing further operations.

See Also **TEC:OUTput?**

TEC:OUTput?

Description TEC output enable query.

Syntax **TEC:OUTput?**

Remarks The **TEC:OUTput?** query returns the status of the TEC output.

Response	Value	Description
<i>enable</i>	0	off
	1	on

Although the status of the switch is on, the output may not have reached the set point value.

See Also **TEC:OUTput**

TEC:R

Description TEC R set point command.

Syntax **TEC:R** *set point*

Remarks The **TEC:R** command sets the TEC constant thermistor set point.

Argument	Description
<i>set point</i>	Thermistor set point in k Ohms

See Also **TEC:R?**

TEC:R?

Description TEC measured R query.

Syntax **TEC:R?**

Remarks The **TEC:R?** query returns the value of the TEC thermistor measurement.

Response	Description
<i>R value</i>	Measured Thermistor resistance in k Ohms

This measurement is updated approximately once every 225 milliseconds.

See Also **TEC:R**

TEC:SENsor?

Description TEC sensor select query.

Syntax **TEC:SENsor?**

Remarks The **TEC:SENsor?** query returns the sensor type. This value is a coded representation of the sensor type/thermistor current. Refer to the The Steinhart-Hart Equation, Section 7.2.1, for further details.

Response	Description	
<i>sensor</i>	1	Thermistor at 100 μ A drive
	2	Thermistor at 10 μ A drive

See Also **TEC:SENsor**

TEC:SET:Ite?

Description TEC ITE set point query.

Syntax **TEC:SET:Ite?**

Remarks The **TEC:SET:Ite?** query returns the TEC constant current set point value.

Response	Description
<i>set point</i>	ITE set point in Amps

See Also **TEC:Ite**

TEC:SET:R?

Description TEC R set point query.

Syntax **TEC:SET:R?**

Remarks The **TEC:SET:R?** query returns the TEC constant thermistor set point value.

Response	Description
<i>set point</i>	Thermistor set point in k Ohms

See Also **TEC:R**

TEC:SET:T?**Description** TEC temperature set point query.**Syntax** **TEC:SET:T?****Remarks** The **TEC:SET:T?** query returns the TEC constant temperature set point value in °C.

Response	Description
<i>set point</i>	Set point in °C

See Also **TEC:T**

TEC:T**Description** TEC temperature set point command.**Syntax** **TEC:T****Remarks** The **TEC:T** command sets the TEC constant temperature set point.

Argument	Description
<i>set point</i>	Set point in °C

See Also **TEC:SET:T?, TEC:T?**

TEC:T?**Description** TEC measured temperature query.**Syntax** **TEC:T?****Remarks** The **TEC:T?** query returns the value of the TEC temperature measurement.

Response	Description
<i>measured temp</i>	Measured temperature in °C

This measurement is updated approximately once every 225 milliseconds.

See Also **TEC:T**

6 Software Application

6.1 Overview

The 350B/500B Controllers have a USB 2.0 connector on the back of the unit that is used to connect to a computer. This connector will work with USB 1.0 and 1.1 also, as it is fully backwards compatible.

Provided on the CD that comes with the unit is an installation for a software application that communicates with the 350B/500B using the USB port. The installation installs the USB drivers that are required to use USB communication.

The design of the software is to allow the user to remotely control the functions of the instrument.

6.2 Connection

Set the USB (Virtual) Address and click the CONNECT button to start communicating with the instrument.

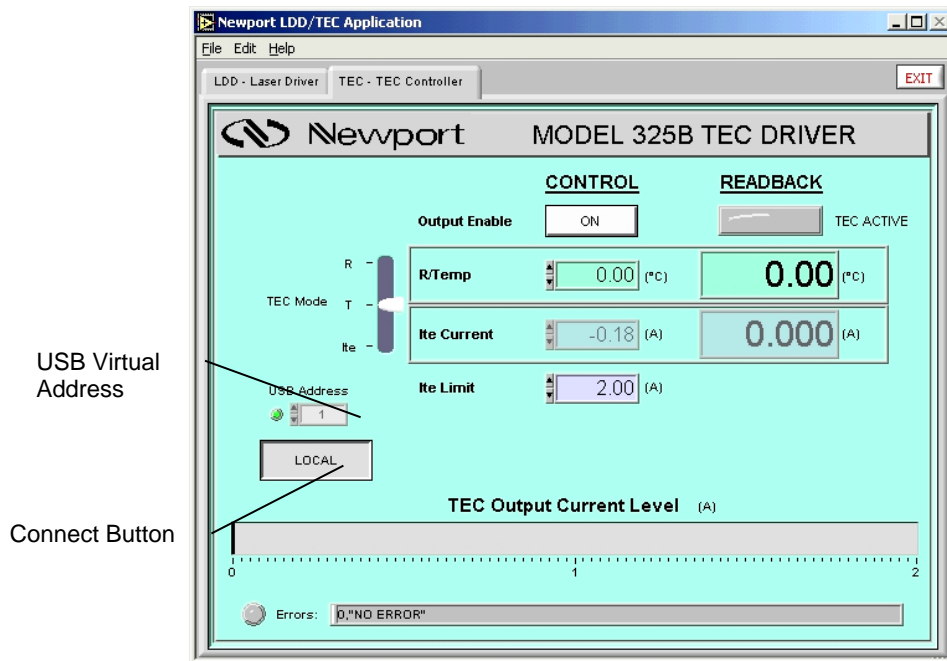

Figure 13

Application front panel (TEC Tab)

6.3 General Usage

This software application allows the user to setup and monitor the instrument remotely. The controls on the instrument are available in the software in a very easy to read and change format.

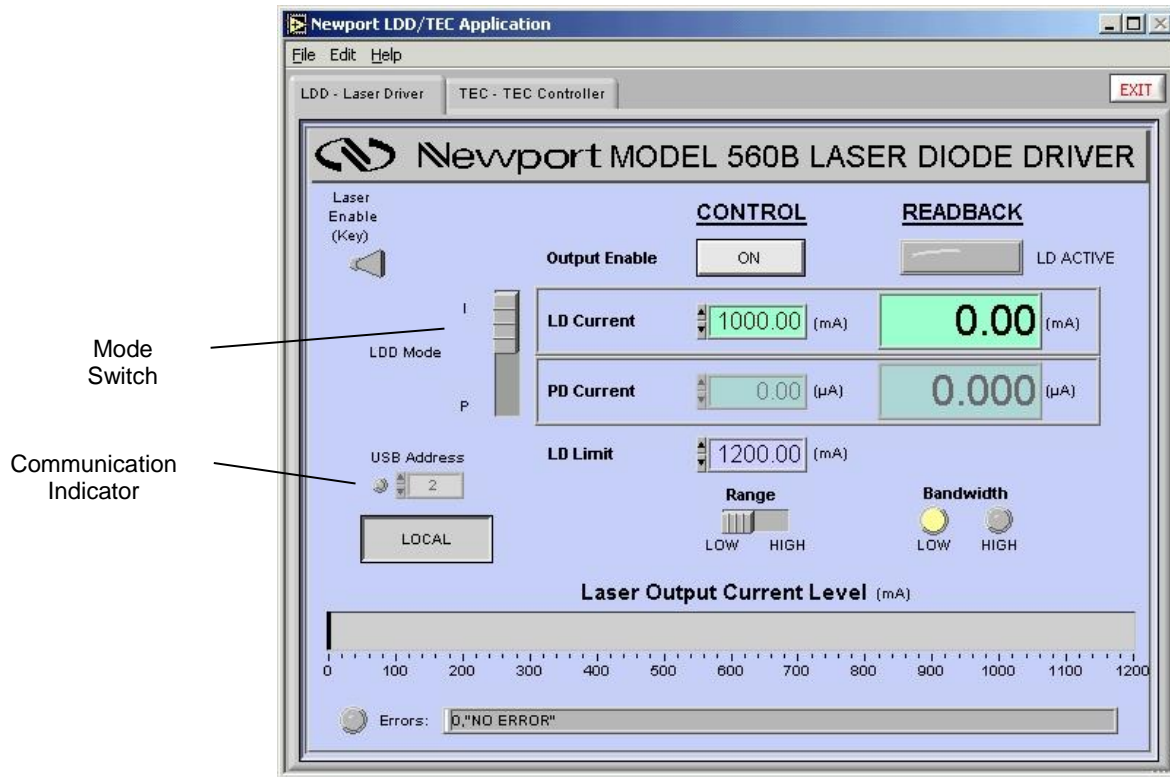

Figure 14 Application front panel when communicating (LDD Tab)

The software has two tabs, one for the (350B) TEC specific functions, and one for the (500B) LDD functions. The individual TEC and LDD specific tabs have two columns labeled on the top as CONTROLS and READBACK.

6.3.1 LDD Tab

CONTROLS:

- | | |
|---------------|---|
| LDD Mode | - Sets I/P mode of control |
| Output Enable | - Turns on/off the output |
| LD Current | - Sets the forward laser current |
| PD Current | - Sets the monitor diode (PD) current |
| LD Limit | - Set the maximum limit for forward current |
| Range | - Set the operating range - Low/High |

READBACK:

Output Enable	- Displays output on/off state
LD Current	- Displays the forward laser current
PD Current	- Displays the monitor diode (PD) current
Bandwidth	- Displays the current bandwidth setting

6.3.2 TEC Tab**CONTROLS:**

TEC Mode	- Sets R/T/I mode of control
Output Enable	- Turns on/off the output
Temp/R	- Sets the Temperature or Resistive setpoint
ITE	- Sets TEC Current
ITE Limit	- Set the maximum limit for TEC current

READBACK:

Output Enable	- Displays output on/off state
Temp/R	- Displays the Temperature or Resistance
ITE	- Displays the TEC Current

The Laser Output Current Level display on the bottom is a visual indicator of the current reading for forward current (LD Current), with the upper limit of LD Limit.

On the very bottom are an Error indicator light and a display of the last Errors, if any.

6.4 Menu Structure

To Exit the application go to the File menu and select Exit.

The Edit/TEC Settings menu option had additional TEC settings, such as PID gain settings.

The Edit/Advanced Properties menu option had additional property settings, including search for instruments and data logging options.

The File/Print will print the window.

The Help/About will show information about the application.

7 Principles of Operation

7.1 Introduction

Three factors must be taken into account when optimizing the operation of a Model 350B Temperature Controller: selection of both the appropriate temperature sensor and TE module heat sink and the manner in which they are mounted. Selecting the proper thermistor to cover a specific temperature range of operation is a simple but important procedure. The proper TE module must be selected to remove the heat dissipated by the laser diode or other device. Finally, the arrangement of the TE module and the heat sink, as well as the heat sink size, are crucial in maximizing the heat transfer efficiency.

7.2 Thermistor

Model 350B Temperature Controller are designed to operate using a thermistor as the temperature sensing device. Temperature is displayed as a resistance ($k\Omega$) corresponding to the temperature of the thermistor. The actual temperature of the thermistor can be determined from the manufacturers curves or tables listing temperature vs. resistance. Two precision current sources, $10\mu A$ and $100\mu A$, are used to generate a voltage across the thermistor and it is this voltage that is read on the front display.

For the $10\mu A$ current source the maximum resistance that can be displayed is $200.0 k\Omega$, while for the $100\mu A$ source the maximum reading is $20.0 k\Omega$.

The minimum resistance value that can accurately be read is 200 ohms ($100\mu A$ current source). These two current values allow a wide range of temperatures to be controlled by the Model 350B Temperature Controller. Different ranges of temperatures can be adjusted for by selecting the proper thermistor value. The following table illustrates this point:

Temperature vs. Thermistor Resistance

Thermistor value @ 25°C	1k	10k	100k
200 $k\Omega$	-75°C	-37°C	-11°C
100 $k\Omega$	-66°C	-24°C	25°C
20 $k\Omega$	-40°C	8°C	65°C
10 $k\Omega$	-27°C	25°C	85°C
1 $k\Omega$	25°C	93°C	>150°C
100 Ω	100°C	>150°C	>150°C
100 Ω	100°C	>150°C	>150°C

Careful thermistor value selection therefore enables control over a wide temperature range.

The temperature resolution and thermistor sensitivity must also be taken into account. Thermistors achieve their highest sensitivity at the lower end of their temperature range. Therefore, the lower the absolute temperature to be maintained, the lower the resistance value the thermistor should be. For example, to operate at 0°C a 5k ohm thermistor would be the best selection while at 100°C a 100k ohm thermistor would be a better selection.

The rule of thumb is to operate the thermistor near the lower end of its temperature range and use the 100µA current bias. Please contact Newport's applications engineers if there are any questions regarding the selection of the proper thermistor for an application. Thermistors have large resistance variations over temperature. Therefore, users should check if the thermistor resistance value over the desired temperature range, times the thermistor current (10µA or 100µA) is inside the voltage span of 0 to 2V for proper operation of the thermal feedback loop. This can be checked by monitoring the voltage at the front panel BNC connector (Analog Output).

7.2.1 The Steinhart-Hart Equation

The Steinhart-Hart equation is used to derive temperature from the non-linear resistance of an NTC (Negative Temperature Coefficient) thermistor.

Two terminal thermistors have a non-linear relationship between temperature and resistance. The resistance versus temperature characteristics for a family of similar thermistors is shown in Figure 15. The resistance-versus-temperature relationship for most common negative temperature coefficient (NTC) thermistors can be accurately modeled by a polynomial expansion relating the logarithm of resistance to inverse temperature. The Steinhart-Hart equation is one such expression and is given as follows:

$$\frac{1}{T} = C_1 + C_2(\ln R) + C_3(\ln R)^3$$

Where T is in Kelvin. To convert T to °C, subtract 273.15.

Once the three constants C_1 , C_2 , and C_3 are accurately determined, only small errors in the calculation of temperature over wide temperature ranges exist. Table 3 shows the results of using the equation to fit the resistance versus temperature characteristic of a common 10 k Ohm (at room temperature) thermistor. The equation will produce temperature calculation errors of less than 0.01°C over the range -20 °C to 50 °C.

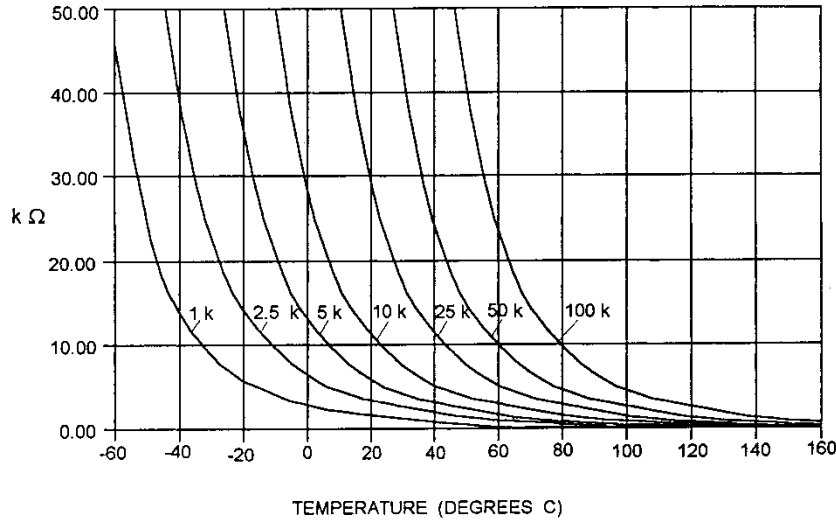

Figure 15 Thermistor Resistance versus Temperature

Error T (°C)		
R ¹	T Actual	Third Order Fit. Eq. 1 ²
97072	-20.00	-0.32
55326	-10.00	-0.06
32650	0.00	0.09
19899	10.00	0.15
12492	20.00	0.13
10000	25.00	0.08
8057	30.00	0.01
5326	40.00	-0.20
3602	50.00	-0.50

Table 3 Steinhart-Hart Curve Fitting Accuracy

The constants C₁, C₂, and C₃ may all be expressed in the form *n.nnn* simplifying entry into the 350B.

7.2.2 Table of Constants

Some common thermistors are listed and included the appropriate calibration constants for the temperature range -20 °C to 50 °C in Table 4. Model 350B, by default, uses the BetaTHERM 10K3A2 thermistor values.

¹ Resistance of a 10K, Fenwal UUA41J1 thermistor.

² Constants

C₁ = 1.125 * 10⁻³

C₂ = 2.347 * 10⁻⁴

C₃ = 0.855 * 10⁻⁷

<i>Manufacturer</i>	C_1*10^{-3}	C_2*10^{-4}	C_3*10^{-7}
BetaTHERM 10K3	1.129241	2.341077	0.877547
BetaTHERM 0.1K1	1.942952	2.989769	3.504383
BetaTHERM 0.3K1	1.627660	2.933316	2.870016
BetaTHERM 1K2	1.373419	2.771785	1.999768
BetaTHERM 1K7	1.446659	2.682454	1.649916
BetaTHERM 2K3	1.498872	2.379047	1.066953
BetaTHERM 2.2K3	1.471388	2.376138	1.051058
BetaTHERM 3K3	1.405027	2.369386	1.012660
BetaTHERM 5K3	1.287450	2.357394	0.950520
BetaTHERM 10K3	1.129241	2.341077	0.877547
BetaTHERM 10K4	1.028444	2.392435	1.562216
BetaTHERM 30K5	0.933175	2.213978	1.263817
BetaTHERM 30K6	1.068981	2.120700	0.901954
BetaTHERM 50K6	0.965715	2.106840	0.858548
BetaTHERM 100K6	0.827111	2.088020	0.805620
BetaTHERM 1M9	0.740239	1.760865	0.686600

Table 4 Thermistor Constants

7.3 Using Thermo-Electric Modules

Thermo-electric (TE) modules are semiconductor devices that act as heat pumps when a voltage is applied to them. This effect is called Peltier cooling or heating. The direction of the current flow determines whether the TE module is cooling or heating a device such as a laser diode or IR detector. A TE module consists of a matrix of thermoelectric couples made of p-type and n-type semiconductor material. A TE module can be fabricated with as few as one couple or with as many as several hundred couples sandwiched between two ceramic plates. The ceramic plates form the top and bottom of the TE module and provide structural integrity as well as electrical insulation from, and thermal conduction to, the heat sink and the device being cooled or heated.

Model 350B Temperature Controller is designed to control the rate and amount of cooling or heating through the use of a feedback loop. The arrangement of the TE module in the cooling mode is shown in Figure 16.

When a positive DC voltage is applied to the n-type element, electrons pass from the p-type to the n-type elements and the temperature decreases as heat is absorbed by the cold side of the TE module. The heat absorbed is proportional to the amount of current flowing through the TE module and the number of p-type and n-type elements in the TE module.

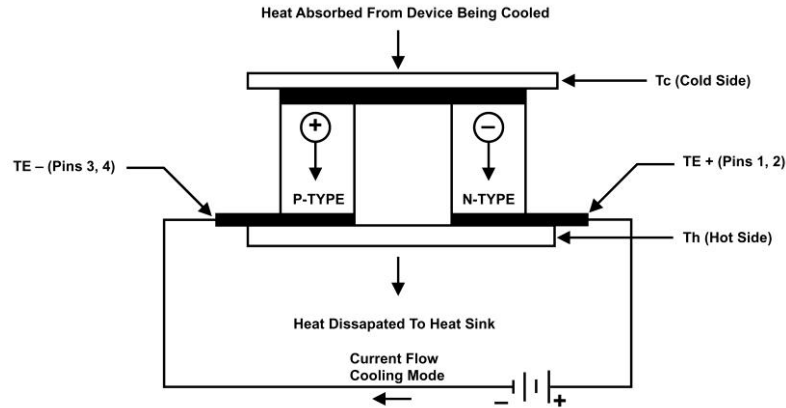

Figure 16 TE Module Configuration

It is necessary to remove the heat from the hot side of the TE module. The amount of heat to be dissipated is equal to the heat pumped from the cold side plus the input power to the TE module. Although the amount of cooling is proportional to the current flowing through the TE module, the power dissipated by Joule heating (input power heating) in the TE module is proportional to the square of the current. Half of this heat must be pumped from the cold side of the TE module. When exceeding a maximum current value (I_{\max}), which is device dependent, the net cooling of the TE module decreases because Joule heating is increasing at a greater rate than Peltier cooling. The manufacturer of the TE module will state the maximum current for each TE module and this current value should not be exceeded.

The LIMIT SET feature on the Model 350B Temperature Controller allows the user to limit the maximum current flowing through the TE module.

7.4 Mounting Considerations

The physical arrangement of the TE module, thermistor, heatsink, and the device to be cooled or heated are crucial to the operation of a Model 350B Temperature Controller. This arrangement determines the thermal load and the rate of heat dissipation to which the control circuitry must respond. To achieve optimum temperature control the thermal path between the device to be cooled or heated and the face of the TE module must be as short as possible and must have high thermal conductivity.

This arrangement also determines the delay that the control circuitry must respond to, and affects the gain setting of the control loop. Another factor that must be taken into account is the mass of the heat sink required to dissipate heat from the TE module. The better the heat sink dissipates heat, thus reducing the thermal gradient across the TE module, the more efficient the TE module is at removing heat from the device being cooled.

Figure 17 shows an arrangement that optimizes the cooling and temperature stability achievable with the Model Temperature Controller.

Two TE modules connected in parallel are shown in the diagram. The actual connection of the TE module depends on the manufacturer's specifications for the voltage drop across the TE module and its current requirement.

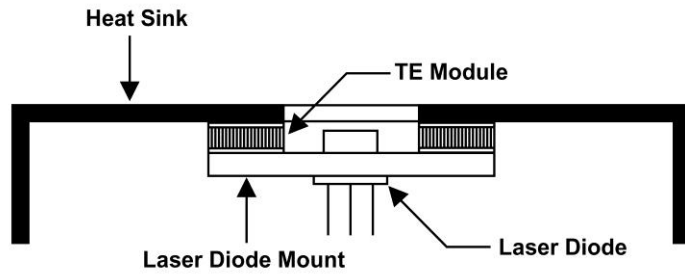

Figure 17 Mounting arrangement of a TE module, heat sink and laser diode

7.5 PID Tuning

The basic block diagram of a temperature control system is shown in Figure 18. The main objective of this control system is to insure that the deviation between actual temperature and desired temperature setpoint is within acceptable limits. The temperature controller attains this by monitoring the actual temperature (output of temperature sensor), comparing this value to a desired setpoint, and driving the TE module (heating/cooling the mount). There are various ways in which the performance of such a control loop can be quantified: settling time, overshoot, etc. In the Model 350B instrument, a PID control algorithm is implemented to achieve optimal stability and settling performance.

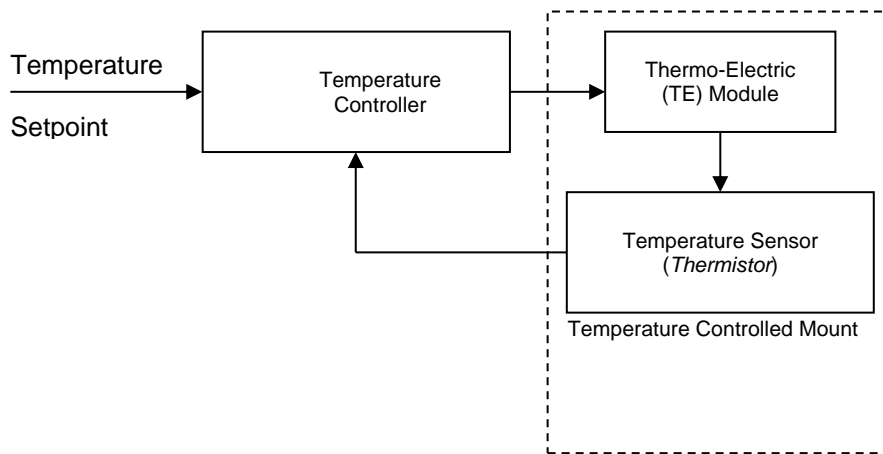

Figure 18 Basic block diagram of a temperature control system

7.5.1 PID Control Loop

The PID term comes from the proportional, integral and derivative gain factors that are at the basis of the control loop calculation. The common equation given for it is:

$$u = K_p \cdot e + K_i \int e \cdot dt + K_d \frac{de}{dt}$$

where:

K_p = proportional gain factor

K_i = integral gain factor

K_d = derivative gain factor

e = instantaneous error

(desired temperature setpoint minus actual temperature)

u = temperature controller

(current that drives the TE module)

The problem for most users is to get a feeling for this formula, especially when trying to *tune* the PID loop. *Tuning* the PID means changing its three gain factors to obtain a certain system response, a challenging task to achieve without some basic understanding of its behavior.

The following paragraphs explain the PID components and their operation.

7.5.2 P Loop

Starting with the simplest type of closed loop control, the **P** (proportional) loop. The diagram in Figure 19 shows its configuration.

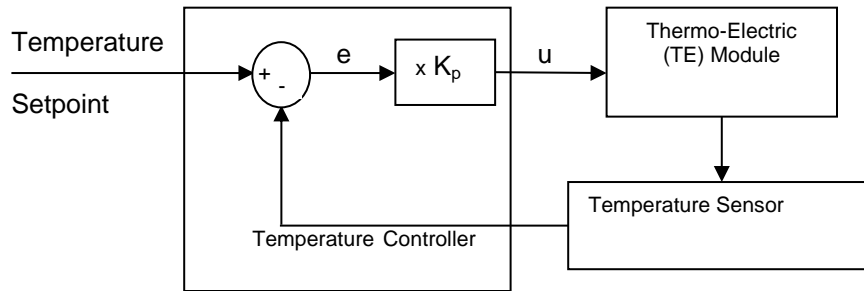

Figure 19 Proportional Temperature Controller Block Diagram

The controller continuously compares the actual temperature, as reported by the temperature sensor, to the desired temperature (setpoint). The difference e is the temperature following error. It amplifies this error (by multiplying it with K_p) and generates a control signal (current) that drives the TE module.

There are a few conclusions that could be drawn from studying this block diagram:

- The control signal is *proportional* to the temperature following error.
- There must be a following error in order to drive the TE module.
- Small errors cannot be corrected if they do not generate enough current for the TE module to overcome any thermodynamic effects from the mounts.
- Increasing the K_p gain reduces the necessary following error but too much of it will generate instabilities and oscillations.

7.5.3 PI Loop

To eliminate the small errors that cannot be compensated by P loop alone, an *integral* term can be added to the control loop. This term integrates (adds) the error continuously and the value, multiplied by the K_i gain factor, is added to the control signal (Figure 20).

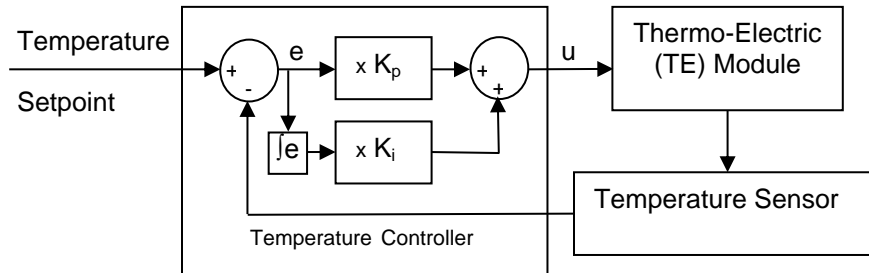

Figure 20 PI Temperature Controller Block Diagram

The result is that the contribution of integral term to the control signal will increase until it reduces the temperature following error to zero. While this is desirable for many situations, the integral term can have a severe destabilizing effect on the control loop if increased too much.

7.5.4 PID Loop

The third term of the PID loop is the *derivative* term. This term amplifies the rate of change of temperature following error by K_d gain factor. If the following error does not change, the contribution of derivative term to the control signal is zero. Figure 21 shows the PID control loop diagram.

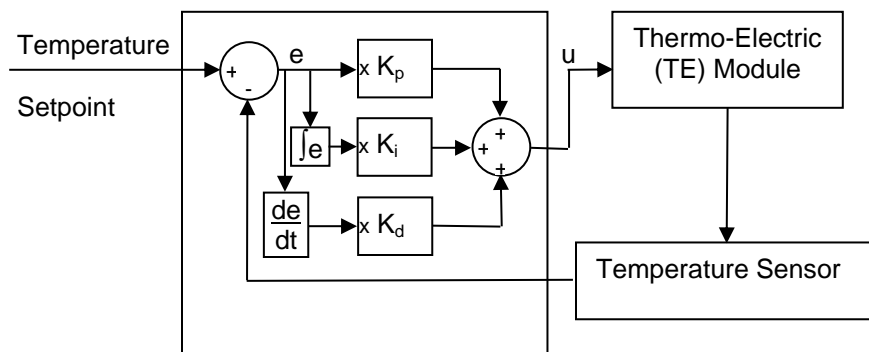

Figure 21 PID Temperature Controller Block Diagram

The derivative term adds a damping effect which helps prevent oscillations and temperature overshoot. It also supports achieving optimal stability and settling time.

7.6 Model 350B Series Setup

Setting up the Model 350B Temperature Controller is a simple procedure.

An AC power cord, supplied with each unit, must be plugged into a properly grounded outlet. The tilt up feet, at the bottom of the unit, may be extended to enhance the viewing angle of the front panel. Connection to TE modules and temperature sensors are made with one of the accessory cables (part #300-02 or #300-04).

7.6.1 Model 350B Operating Checklist

The following steps should be followed when operating a Model 350B Series Temperature Controller.

- a. Check the AC voltage selection of the unit to be sure that it is compatible with the outlet to be used. All units are factory preset for operation from 108–132VAC.
- b. Connect the temperature sensor and TE module to the 15-pin output connector.
- c. Check that the proper temperature sensor bias is selected.
- d. Turn on the AC power switch and the unit will start-up with the output to the TE module off. The display will be in the PRESET mode.
- e. Before setting any values on the DISPLAY select the operating mode, R/T or I_{TE} .
- f. Change the display to the LIMIT display mode and set the maximum current allowed to the TE module. For this, push the display button until the LIMIT SET LED is lit. Turn the control knob until the display shows the desired limit current.

NOTE

The maximum current is specified by the manufacturer and must not be exceeded or damage to the TE module may occur.

- g. If the operating set-point has not been set or needs to be changed, select the PRESET display mode and use the control knob to set the correct value. The operating temperature, resistance or TE current is set before turning the OUTPUT on.
- h. The OUTPUT can now be turned on and the Model 350B Temperature Controller will automatically control the temperature or I_{TE} . Push the OUTPUT switch once to turn the current on to the TE module and a second time to turn the current off. If there is an error condition the current will not turn on and the ERROR indicator LED will come on. If this occurs verify that the temperature sensor and TE connections are correct. After an ERROR condition has occurred the OUTPUT switch must be pushed once to reset the control circuitry. After the fault is corrected and the circuitry is reset the OUTPUT switch can be pushed a second time and the output current will turn on.
- i. During the operation of the Model 350B Temperature Controller any of the parameters may be displayed and the status of the Model 350B Series Temperature Controller may be monitored.

NOTE

Newport Corporation is not in any way responsible for any damage to any device used in conjunction with the Model 350B.

8 Maintenance and Service

CAUTION

There are no user serviceable parts inside the Model 350B Temperature Controller. Work performed by persons not authorized by Newport Corporation will void the warranty.

8.1 Enclosure Cleaning

WARNING

Before cleaning the enclosure of the Model 350B Temperature Controller, the AC power cord must be disconnected from the wall socket.

The enclosure may be cleaned with a soft cloth dampened with either a mild soapy water solution or Isopropyl Alcohol. Do not use any other chemicals or solutions.

8.2 Fuse Replacement

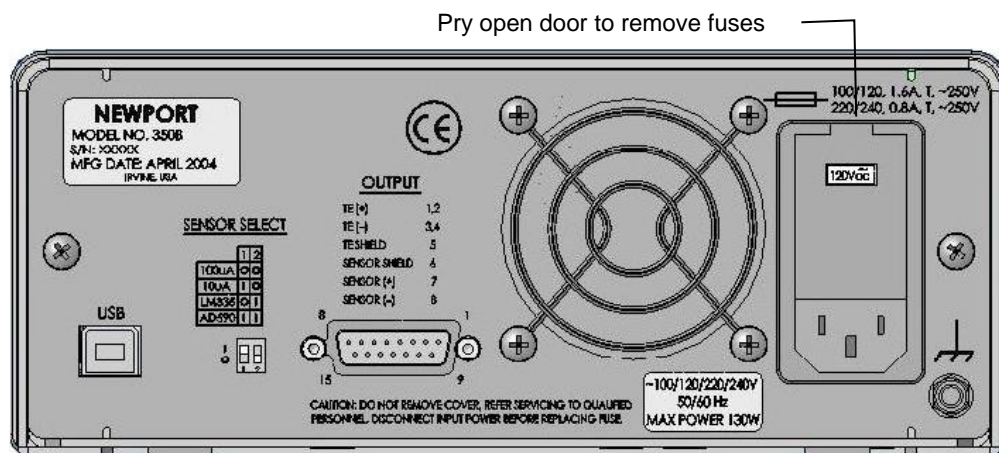



Figure 22 Fuse Location

	<p>WARNING</p> <p>To reduce the risk of electric shock or damage to the instrument, turn the power switch off and disconnect the power cord before replacing a fuse.</p>
---	---

If a fuse blows:

1. Disconnect the power cord from the controller
2. Pry open tab at top of power receptacle and open panel to access fuses.
(See Figure 22)

3. Replace the fuse(s).

Use only 5mm x 20mm fuses as indicated below

<u>Fuse Replacement</u>	<u>Line Voltage</u>
1.6 Amp, (T), 250V	100/120VAC
0.8 Amp, (T), 250V	220/240VAC

4. Reconnect the power cord and turn on the instrument.
5. If the problem persists, contact Newport Corporation for service.

8.3 Obtaining Service

The Model 350B Temperature Controller contains no user serviceable parts. To obtain information regarding service, contact Newport Corporation or a Newport representative. Please have the following information available:

1. Instrument model number (on the rear panel)
2. Instrument serial number (on rear panel)
3. Description of the problem.

If the instrument is to be returned to Newport Corporation, a Return Number will be issued, which should be referenced in the shipping documents. Please fill out a copy of the service form, located on the following page, and have the information ready when contacting Newport Corporation. Return the completed service form with the instrument.

8.4 Service Form



Newport®
Experience | Solutions

Newport Corporation
U.S.A. Office: 800-222-6440
FAX: 949/253-1479

Name _____ **Return Authorization #** _____
(Please obtain RA# prior to return of item)

Company _____
(Please obtain RA # prior to return of item)

Address _____ Date _____

Country _____ Phone Number _____

P.O. Number _____ FAX Number _____

Item(s) Being Returned:

Model # _____ Serial # _____

Description _____

Reason for return of goods (please list any specific problems):

Notes:

**Newport Corporation
Worldwide Headquarters**

1791 Deere Avenue
Irvine, CA 92606

(In U.S.): 800-222-6440
Tel: 949-863-3144
Fax: 949-253-1680

Internet: sales@newport.com



Newport®

Experience | Solutions

Visit Newport Online at: www.newport.com