

RoHS 2 Compliant

502A-J

4-20 MA THERMOCOUPLE TRANSMITTER

10632ML-01



This device is marked with the international hazard symbol. It is important to read the Setup Guide before installing or commissioning this device as it contains important information relating to safety and EMC.

It is the policy of NEWPORT to comply with all worldwide safety and EMC/EMI regulations that apply. NEWPORT is constantly pursuing certification of its products to the European New Approach Directives. NEWPORT will add the CE mark to every appropriate device upon certification.

© Copyright 1998, NEWPORT Electronics, Inc. All rights reserved.

This documentation may not be copied, photocopied, reproduced, translated, or reduced to any electronic medium or machine-readable form, in whole or in part, without prior written consent of NEWPORT Electronics, Inc.

CHG	ECO NO	DATE	BY
D	9261	22 JAN 98	ML

TABLE OF CONTENTS

SAFETY CONSIDERATIONS	ii
1.0 GENERAL INFORMATION	1
Accuracy and Stability	1
Adaptability/Turndown	1
Electrical Isolation	1
Shock Resistance	1
Waterproof/RFI/Thermal Gradient Resistant Case	1
Mounting Adaptability	1
2.0 SPECIFICATIONS	2
Input	2
Output	2
Accuracy	2
Environmental	2
Mechanical	2
3.0 MECHANICAL ASSEMBLY AND INSTALLATION	3
Unpacking and Inspection	3
Safety Considerations	3
Optional Adapters for Mounting	6
Bulkhead and TR2/2TK Relay Track Mounting Procedure	6
DIN EN-50 022 Relay Track Mounting Procedure	7
External Explosion-Proof Housing Mounting Procedure	8
4.0 POWER AND SIGNAL INPUT CONNECTIONS	9
5.0 CONFIGURATION	10
Tools and Equipment	10
Calibration Procedure, Ambient Temperature	10
Calibration Procedure, Ice-Point Cell	12
Pin Assignments	16
Calibration Formula	16
6.0 DRAWINGS	17
ILLUSTRATIONS		
Figure 3-1 Exploded View of Model 502A	4
Figure 3-2 Case Dimensions	5
Figure 3-3 Bulkhead and Track Mounting	6
Figure 3-4 DIN Track Mounting	7
Figure 3-5 Spring Retainer for Explosion-Proof Housing	8
Figure 4-1 Power Input Connections	9
Figure 5-1 Calibration Setup Using Ambient Temperature	10
Figure 5-2 Calibration Setup Using Ice-Point Cell	12
Figure 5-3 Jumper Diagram	16
Figure 6-1 502A Preamp Block Diagram	17
Figure 6-2 502A Postamp Block Diagram	17
Table 5-1 Type J Thermocouple Reference Table	10
Table 5-2 Celsius Temperature Ranges Obtained with Jumpers	15
APPENDICES		
Appendix A Transmitter Accuracy Factors	18

1.0 GENERAL INFORMATION

The 502A-J two-wire transmitter takes in millivolt signals generated by a type J thermocouple, provides cold (reference) junction compensation, amplification, common-mode isolation, and controls the current drawn from a 9 to 50 V dc source to produce the 4 to 20 milliampere output signal.

Common-mode voltage between the input thermocouple and the output current circuit is tested at 1500 V rms. As much as 750 ohms dropping resistance or 625 ohms in series with a loop-powered indicator (Newport model 508A) may be used in the power leads of the 502A when the unit is energized from a 24 V dc source. This is because of the small compliance voltage needed by the unit. Accidental overloads of over one minute by 120 V rms on either input or output leads do not damage the 502A.

1.1 ACCURACY AND STABILITY

The 502A-J has tailored resistance values installed to provide curvi-linear cold-junction compensation matched to the NBS or IEC type J thermocouple table. Selected bridge resistors in a temperature-sensing bridge also provide cancellation of Span temperature effects. The unit is certified for accuracy from -40 to +85°C (-40 to +185°F) through verification of high-ambient-temperature compensation points.

1.2 ADAPTABILITY/TURNDOWN

The Span of the 502A-J can be ranged anywhere from 100 to 800°C by selection of one of four jumper positions, with fine tuning provided by a multiturn, top-accessible potentiometer. Sixteen Zero steps, also provided by 502A-J jumpers, allow placement of the 4.00 mA output temperature anywhere from -50 to 700°C, with fine tuning provided by another top-accessible, multiturn potentiometer. This 502A turndown capability exceeds that of any other known transmitter.

1.3 ELECTRICAL ISOLATION

502A input (thermocouple and shield) and output (DC power) barrier strips accept wires up to two millimeters in diameter (13 gauge), and are mechanically isolated from each other to prevent input/output wiring contact during installation.

1.4 SHOCK RESISTANCE

Lightweight 502A circuit boards are formed into a rigid box structure and firmly soldered and epoxied to the case top. The circuit-board box is doubly coated with RTV silicone for environmental protection. When installed in the rugged, die-cast case, the 502A can withstand the shock of a 6-foot drop onto a hard surface (although scarring of the case and/or deformation of the plastic cover can occur).

1.5 WATERPROOF/RFI/THERMAL GRADIENT RESISTANT CASE

The 502A case is made from Zamac (zinc alloy), coated with polyurethane, and gasketed with fluorosilicone. Fluorosilicone plugs protect the top-access Span and Zero potentiometers. An optional opaque top cover shields the barrier strips from uneven heating or cooling in exposed environments.

1.6 MOUNTING ADAPTABILITY

The small size of the 502A (less than 75 mm or 3 in. outside diameters) permits snap mounting into the American 8TK2 relay track or wall mounting in confined areas. With a bulkhead adapter, the 502A can be snap mounted into the larger American TR2/2TK relay track or wall mounted by rotating the adapter 90 degrees. With the use of the rail clamp adapter, the 502A may be mounted onto the narrow DIN EN-50-022 relay track. Using the spring retainer option, the 502A can be mounted into explosion-proof housings.

2.0 SPECIFICATIONS

2.1 INPUT

Configuration:	Isolated input
Thermocouple type:	J ("Iron/Constantan")
Input impedance:	5 MOhm
Thermocouple break-detect current:	50 nA max
Burnout indication:	Selectable up or down overscale
Thermocouple lead resistance:	Up to 500 ohms for specified performance
Normal mode rejection:	60 dB at 50/60 Hz with 100 mV input
Common mode voltage, input to case or output:	2100 V peak per high pot. test; 354 V peak per IEC spacing
Common mode rejection, input to case or output:	100 dB min from DC to 60 Hz
Overvoltage protection:	120 V ac max/1 min exposure

2.2 OUTPUT

Linear range:	4 to 20 mA dc
Compliance (supply-voltage):	9 to 50 V dc
Overvoltage protection:	120 V ac
Reverse polarity protection:	400 V peak
Common mode voltage, output to case or input:	2100 V peak per high pot. test; 354 V peak per IEC spacing
Common mode rejection, output to case or input:	100 dB min from DC to 60 Hz

2.3 ACCURACY

Hysteresis and repeatability:	Within $\pm 0.2^{\circ}\text{C}$ $\pm 0.1\%$ of Span
Conformity, 100°C Span:	$\pm 1^{\circ}\text{C}$
Six month stability:	Within $\pm 0.2^{\circ}\text{C}$ $\oplus 0.2\%$ of 4 mA temperature
Power supply effect	Within $\pm 0.005\%/V$
Ambient temperature effect for 50°C change:	Zero and conformity: Within $\pm 0.5^{\circ}\text{C}$ Span: Within 0.3% Suppression: $\pm 0.2\%$ of 4 mA temperature
Cold Junction:	Zero Error: $\pm 0.04^{\circ}\text{C}/^{\circ}\text{C}$ Typical Span Error: $\pm 0.03^{\circ}\text{C}/^{\circ}\text{C}$ Typical

2.4 ENVIRONMENTAL

Operating temperature:	-40 to 85°C
Storage temperature:	-55 to 125°C
Humidity:	To 100%
Vibration:	1.52 mm (.06 in) double amplitude, 10-80 Hz cycled
Shock:	55g, half-sine, 9-13 msec duration, 6' drop to hard surface
Watertight pressure limit:	35 kPa (5 psi)
Mounting position:	Any

2.5 MECHANICAL

Case material:	Zamac ^o (zinc alloy), polyurethane-coated, fluorosilicone-gasketed
Weight:	300 g (10 oz)
Diameter:	74 mm (2.9 in)
Height (including barriers):	52 mm (2.1 in)
Connections:	#6 screws with wire clamps

3.0 MECHANICAL ASSEMBLY AND INSTALLATION

3.1 UNPACKING AND INSPECTION

Your 502A-J was systematically inspected and tested, then carefully packed before shipment. Unpack the instrument and inspect for shipping damage. If possible, remove the casing and visually inspect the internal circuitry. Notify the freight carrier immediately if damage exists.

Each package includes an assembled transmitter and an owners' manual. If any items are not according to your order, contact your local distributor or Newport Electronics.

3.2 SAFETY CONSIDERATIONS

As delivered from the factory/distributor, this instrument complies with required safety regulations. To prevent electrical or fire hazard and to ensure safe operation, please follow the guidelines below.

VISUAL INSPECTION: Do not attempt to operate the unit if damage is found.

MOUNTING: Observe the mounting instructions in the following pages, as applicable.

POWER VOLTAGE: Verify that the instrument is connected for the power voltage rating that will be used (9-50 V dc). If not, make the required changes as indicated in Section 4.

POWER WIRING - This instrument has no power-on switch; it will be in operation as soon as the power is connected.

SIGNAL WIRING - Do not make signal wiring connections or changes when power is on. Make signal connections before power is applied. Disconnect the power before making connection changes.

EXERCISE CAUTION - As with any electronic instrument, high voltage may exist when attempting to install, calibrate, or remove parts of the transmitter.

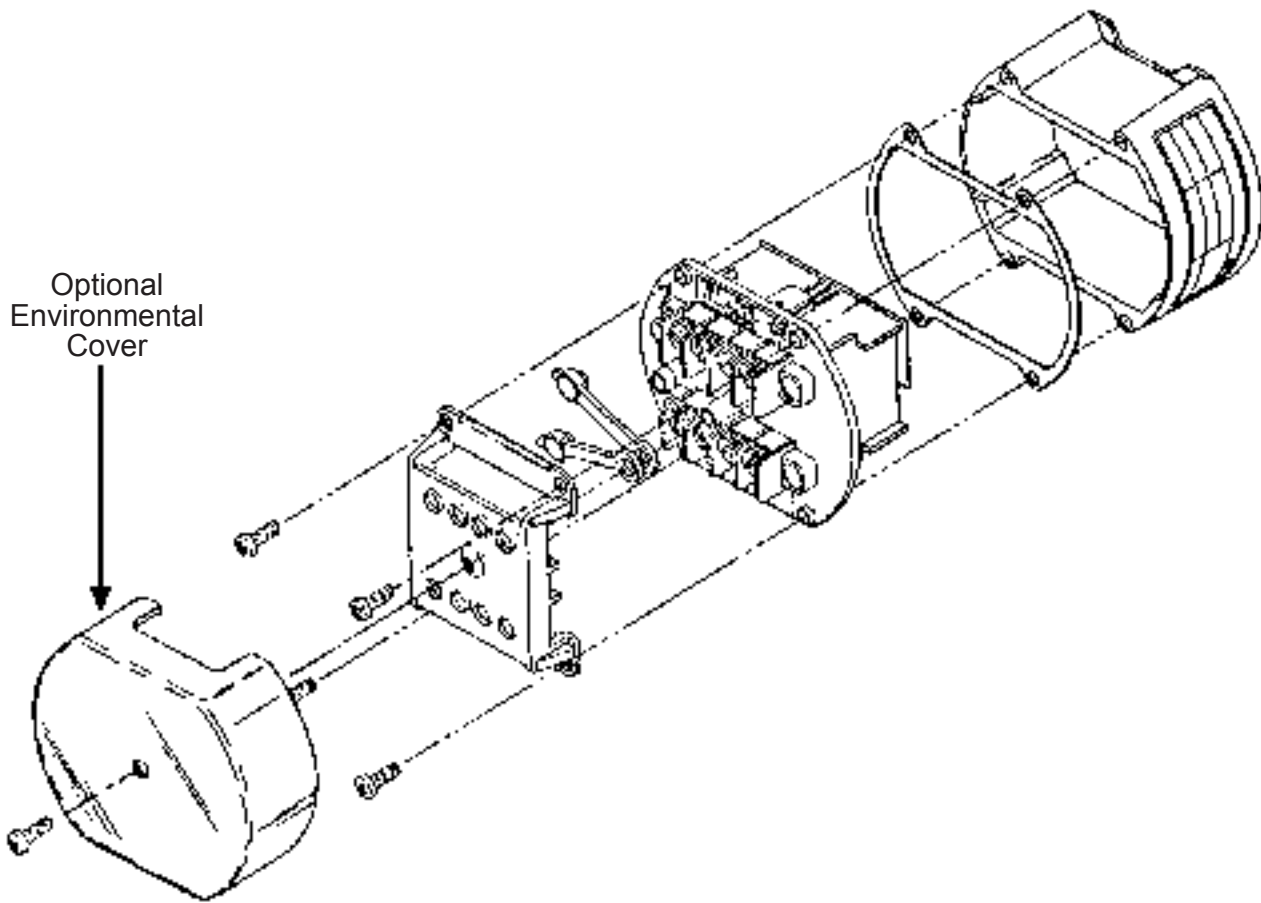
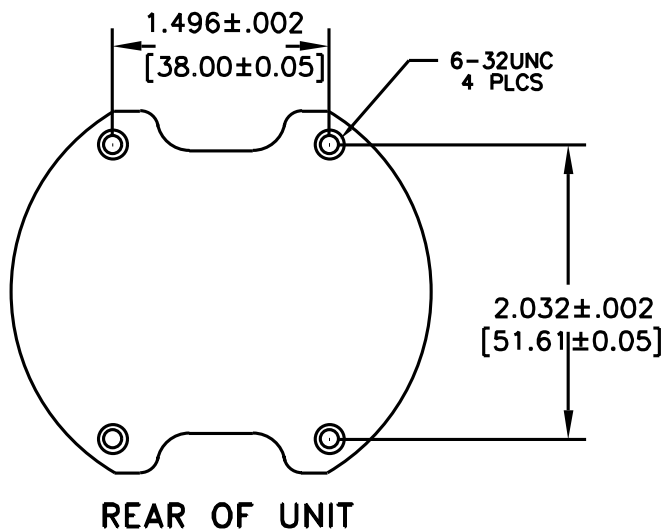
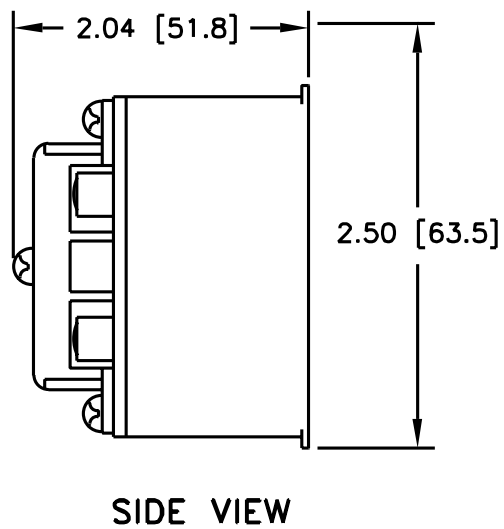
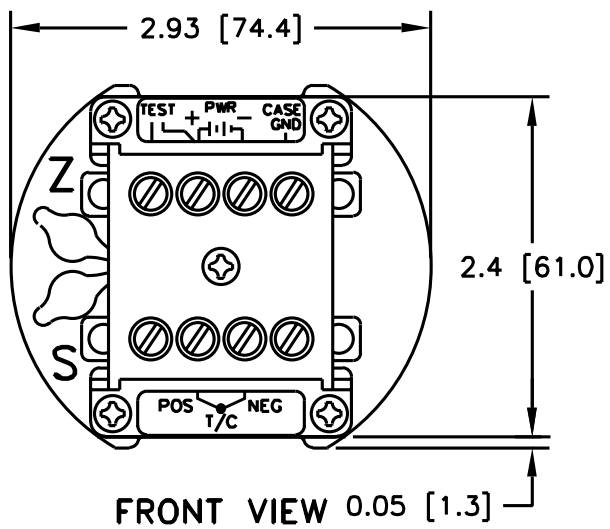

Figure 3-1 Exploded View of Model 502A



Four tapped holes with #6-32 screw threads on the rear of the case provide behind-the-wall access for bulkhead mounting; flanges on the rear of the case snap into the American 8TK2 rail for track mounting.

Figure 3-2 502A Case Dimensions

3.3 OPTIONAL ADAPTERS FOR MOUNTING

The following optional adapters provide various mounting choices:

- a. Adapter plate for either front-screw-entry surface mount or TR2/2TK relay track mount. See Figure 3-3.
- b. Rail clamp for DIN EN-50-022 relay track mount. See Figure 3-4.
- c. Spring retainer for explosion-proof housings that have internal diameters of 76.4 to 88.9 mm (3.0 to 3.5 in.). See Figure 3-5.

For ordering purposes, the options are identified as follows:

Adapter plate	MAT1
Rail Clamp	MDT1
Spring Retainer for Explosion-proof or Waterproof housing	MXS1
Explosion-proof/ Waterproof housing	EPH (Includes MXS1)

3.4 SURFACE AND TR2/2TK RELAY TRACK MOUNTING PROCEDURE

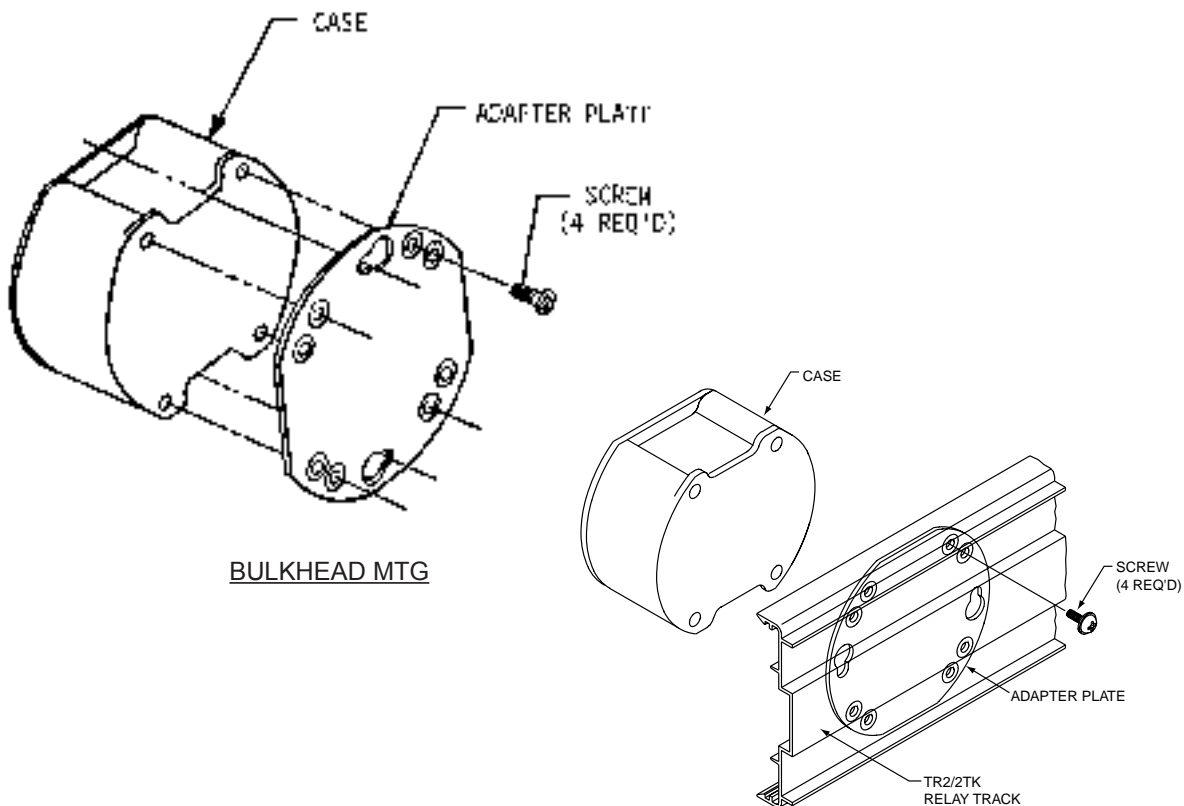
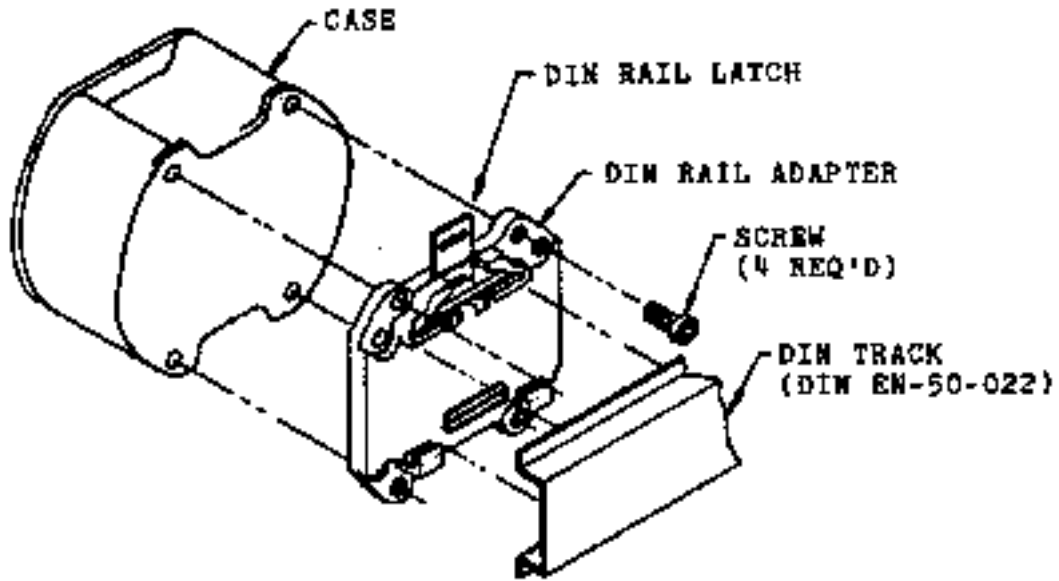

Figure 3-3 Bulkhead and Track Mounting

1. Position plate for desired application.
2. Use #6 hardware to mount plate to back of 502A case.

3.5 DIN EN-50-022 RELAY TRACK MOUNTING PROCEDURE



DIN TRACK MOUNTING: SHOWN FOR HORIZONTAL TRACK

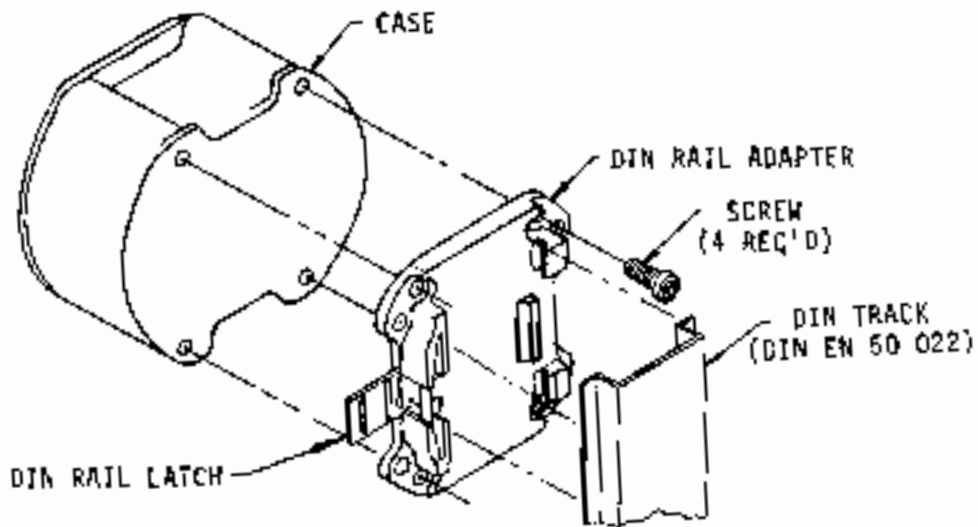

DIN TRACK MOUNTING: SHOWN FOR VERTICAL TRACK

Figure 3-4 DIN Track Mounting

1. Position adapter for desired track direction.
2. Use #6 screws to mount adapter to back of 502A case.
3. Snap 502A case assembly onto DIN rail.

3.6 EXTERNAL EXPLOSION-PROOF HOUSING MOUNTING PROCEDURE

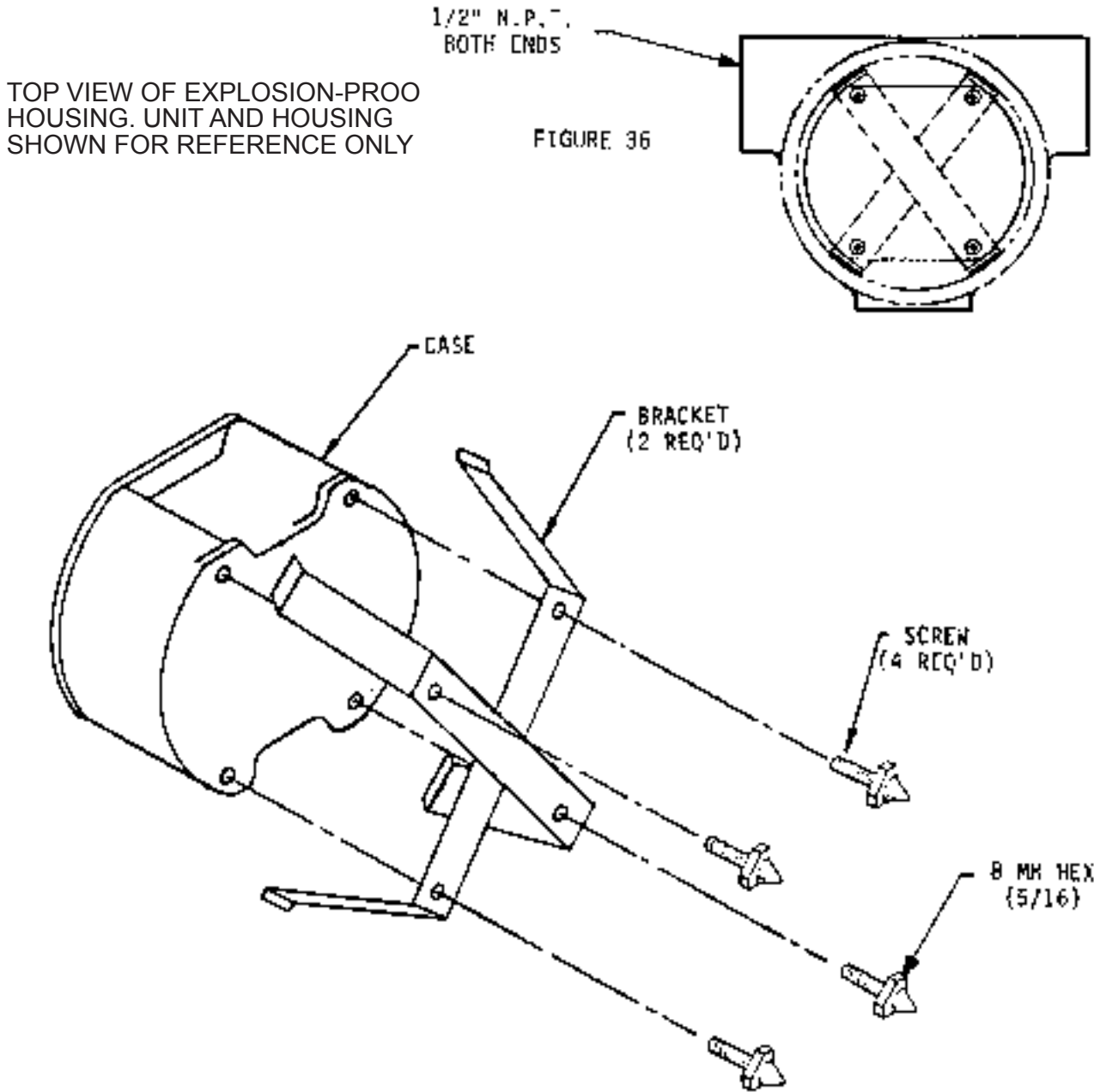

Figure 3-5 Spring Retainer for Explosion-Proof Housing

1. Position spring retainer across back of 502A case.
2. Use wire protector feet (four provided with above option) to hold spring retainers in place.
3. Press 502A case assembly into explosion-proof housing.

4.0 POWER AND SIGNAL INPUT CONNECTIONS

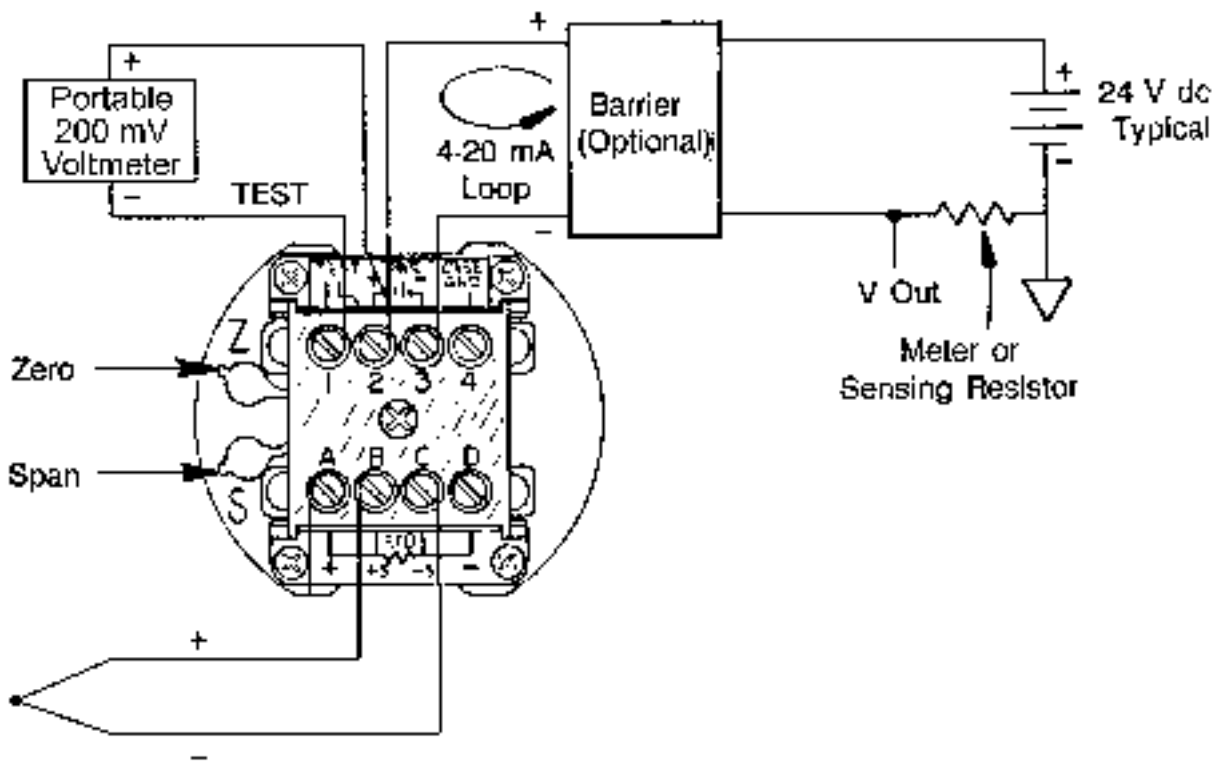

Figure 4-1 Power Input Connections

TEST, PWR +, and PWR - screws accept 2 mm (13 gauge) or lighter wire. CASE GND is grounded to the case. Power input range is 9-50 V dc.

SCREW-TERMINAL PIN ASSIGNMENT

- 1 Test
- 2 + Power Output
- 3 - Power Output
- 4 Case Ground

- A No Connection
- B + Thermocouple Input
- C - Thermocouple Input
- D No Connection

5.0 CONFIGURATION

The 502A-J is normally delivered configured for 4/20 mA = 0/500°C.

5.1 TOOLS AND EQUIPMENT

#1 Phillips screwdriver
3/32" flat blade screwdriver, VACO 17764 or equivalent
4 1/2 digit DVM (digital voltmeter)
10 or 100 ohms 1% resistor
Fixed or variable DC power supply or battery (range of 11-30 V dc) -3000 to 55000 uV source
Precision thermometer

KAYE 140 or equivalent 0°C ice-point cell (Optional)

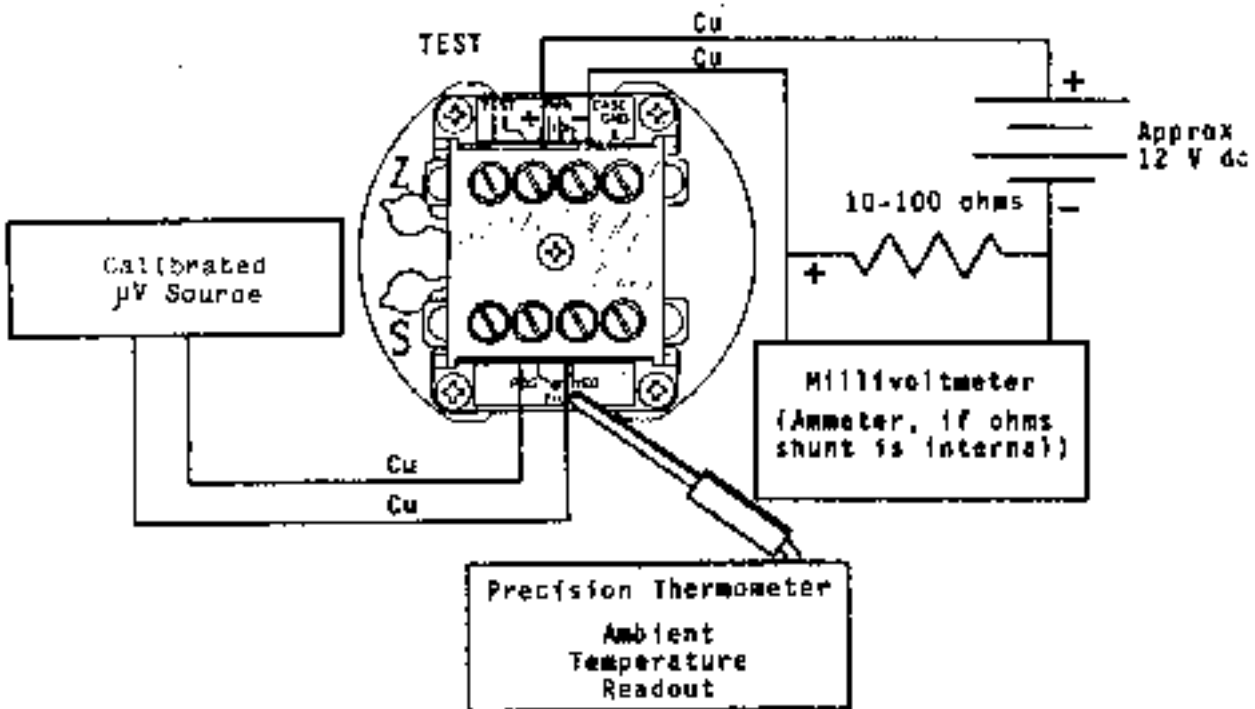

Figure 5-1 Calibration Setup Using Ambient Temperature

5.2 CALIBRATION PROCEDURE, AMBIENT TEMPERATURE

1. Remove the outer four screws from the case top and lift out the electronics assembly (attached to the case lid).
2. Pull out the two sealing plugs which cover the Span and Zero potentiometers (**S pot** and **Z pot**). Adjust the S pot five turns clockwise (CW) from the fully counter-clockwise (CCW) position.

NOTE: S pot and Z pot are both multi-turn pots; 25 complete turns in a CCW direction will ensure that the pot is fully CCW.

3. Using Table 5-2, select the range which comes closest to your desired 4 and 20 mA temperatures. Note which Zero and Span jumpers are called out in the table for the range selected.
4. Turn the unit so that the jumper pin-forest is in view, and install the push-on jumpers on the positions indicated (see Figure 5-3). Place the unused jumpers in storage positions.

5. Refer to Figure 5-1 and connect the transmitter to the power supply, microvolt source, current shunt, and milliammeter. Place the temperature probe as close as possible to the 502A-J input terminals. **Better calibration stability is obtained if the electronic assembly is configured while in the case.**
6. Using Table 5-1, determine the microvolt level that the ambient (Room) temperature represents. Subtract this from the microvolt level corresponding to the desired 4.00 mA temperature, found in Table 5-1. This value is **LO-IN**.
7. Set the microvolt calibration source to LO-IN microvolts and adjust the Z pot until the milliammeter reads 4.00 mA.
8. Using the previously determined microvolt level of the ambient (Room) temperature, subtract this from the microvolt level corresponding to the desired 20.00 mA temperature (Table 5-1). This value is **HI-IN**.
9. Set the microvolt calibration source to HI-IN microvolts and read the output current on the milliammeter. This current level is designated **Initial Top Current (ITC)**, normally not equal to 20.00 mA.
10. Calculate the **Corrected Top Current (CTC)** with the following equation (generally this will not equal 20.00 mA).

$$CTC = 16 \cdot ITC / (ITC - 4 \text{ mA})$$
11. Adjust the S pot to obtain the Corrected Top Current on the milliammeter.
12. Now readjust the Z pot so that the milliammeter reads 20.00 mA.
13. Set the microvolt source to LO-IN microvolts. If the output current is not 4.00 mA, repeat steps 7 through 12.
14. When calibration is complete, remove the transmitter from the setup and replace the sealing plugs. Reinstall the unit in the case and ensure that the four screws are tightened enough to compress but not flatten the gasket.

EXAMPLE:

Temperature Range = -58 to 662°F or -50 to 350°C *

* Conversion Formula for Fahrenheit to Celsius: $(^{\circ}\text{F} - 32) \times 5/9 = ^{\circ}\text{C}$

Zero Jumper required, D (Table 5-2)

Span Jumper required, None (Table 5-2)

4.00 mA Output = -50°C or -2431.0 uV (Table 5-1)

20.00 mA Output = 350°C or 19088.5 uV (Table 5-1)

Ambient Temperature = 25°C or 1277.0 uV (Table 5-1)

LO-IN = -2431.0 - 1277.0 = -3708.0 uV

HI-IN = 19088.5 - 1277.0 = 17811.5 uV

For specific values not given in Table 5-1, interpolation may be used.

Calibration steps:

1. Adjust the S pot five turns CW from a fully CCW position.
2. Set microvolt source to -3708.0 uV.
3. Adjust the Z pot so that the milliammeter reads 4.00 mA.
4. Set microvolt source to 17811.5 uV.
5. Read the Initial Top Current.
6. Calculate the Corrected Top Current.
7. Adjust the S pot to obtain the Corrected Top Current.
8. Adjust the Z pot to obtain a 20.00 mA current reading.
9. Set microvolt source to -3708.0 uV.
10. If the output is not 4.00 mA, repeat steps 2 through 9.

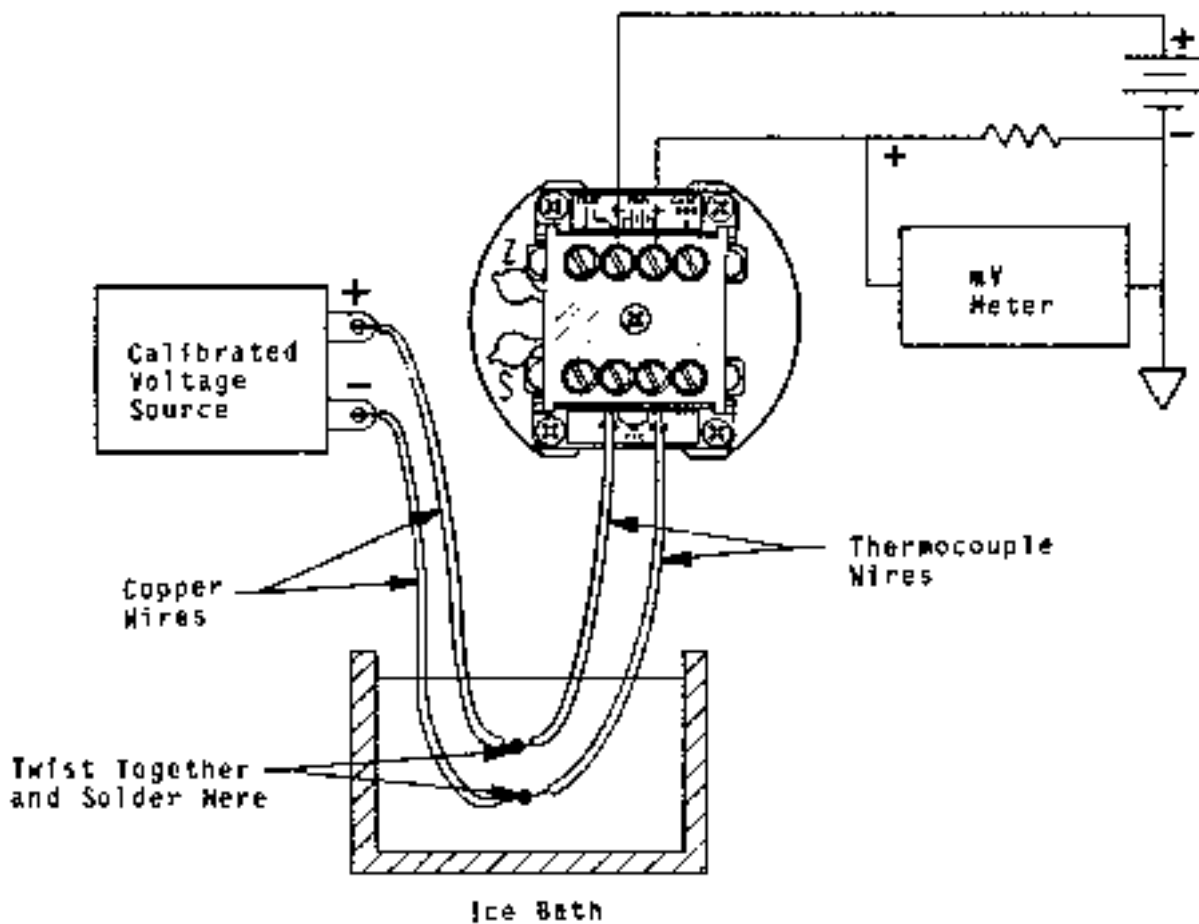

Figure 5-2 Calibration Setup Using Ice-Point Cell

5.3 CALIBRATION PROCEDURE, ICE-POINT CELL

1. Remove the outer four screws from the case top and lift out the electronics assembly (attached to the case lid).
2. Pull out the two sealing plugs which cover the Span and Zero potentiometers (S pot and Z pot). Adjust the S pot five turns clockwise (CW) from the fully counter-clockwise (CCW) position.

NOTE: S pot and Z pot are both multi-turn pots; 25 turns in a CCW direction will ensure that the pot is fully CCW.

3. Using Table 5-2, select the range which comes closest to your desired 4.00 and 20.00 mA temperatures. Note which Zero and Span jumpers are called out in the table for the range selected.
4. Turn the unit so that the jumper pin-forest is in view and install the push-on jumpers on the positions indicated (see Figure 5-3). Place the unused jumpers in storage positions.

5. Refer to Figure 5-1 and connect the transmitter to the power supply, microvolt source, current shunt, and milliammeter. Ensure that the copper wires from the millivolt source and the thermocouple wires from the 502A-J are soldered together and immersed in the ice bath. **Better calibration stability is obtained if the electronic assembly is configured while in the case.**
6. Using Table 5-1, determine the microvolt level corresponding to the desired 4 mA temperature. This value is **LO-IN**.
7. Set the microvolt calibration source to LO-IN microvolts and adjust the Z pot until the milliammeter reads 4.00 mA.
8. Determine the microvolt level corresponding to the desired 20.00 mA temperature. This value is **HI-IN**.
9. Set the microvolt calibration source to HI-IN microvolts and read the output current on the milliammeter. This current level is designated **Initial Top Current (ITC)**, normally not equal to 20.00 mA.
10. Calculate the Corrected Top Current (CTC) with the following equation (generally this will not equal 20.00 mA).

$$CTC = 16 \cdot ITC / (ITC - 4 \text{ mA})$$

11. Adjust the S pot to obtain the Corrected Top Current on the milliammeter.
12. Now readjust the Z pot so that the milliammeter reads 20.00 mA.
13. Set the microvolt source to LO-IN microvolts. If the output current is not 4.00 mA, repeat steps 7 through 12.
14. When calibration is complete, remove the transmitter from the setup and replace the sealing plugs. Reinstall the unit in the case and ensure that the four screws are tightened enough to compress but not flatten the gasket.

Type J Thermocouple Output Voltage, E, and Slope Sensitivity or Seebeck Coefficient, S, per NBS Monograph 125 (Based on IPTS-68) or IEC publication 584-1, dated 1977.

T °C	E uV	S uV/°C	T °C	E uV	S uV/°C	T °C	E uV	S uV/°C
-50	-2431.0	46.615	130	6907.1	54.910	580	31932.7	57.849
-40	-1960.4	47.491	140	7456.9	55.050	590	32512.7	58.165
-30	-1481.4	48.301	150	8008.1	55.170	600	33096.0	58.496
-20	-994.6	49.049	160	8560.3	55.270	610	33682.7	58.841
-10	-500.6	49.738	170	9113.4	55.351	620	34272.9	59.198
0	0.0	50.373	180	9667.2	55.417	630	34866.7	59.567
10	506.7	50.956	190	10221.7	55.466	640	35464.3	59.944
11	557.7	51.012	200	10776.5	55.502	650	36065.6	60.328
12	608.7	51.067	210	11331.7	55.525	660	36670.8	60.715
13	659.8	51.122	220	11887.0	55.536	670	37279.9	61.103
14	711.0	51.176	230	12442.4	55.537	680	37892.9	61.489
15	762.2	51.229	240	12997.7	55.529	690	38509.7	61.869
16	813.4	51.283	250	13552.9	55.514	700	39130.2	62.239
17	864.7	51.335	260	14107.9	55.491	710	39754.4	62.594
18	916.1	51.388	270	14662.7	55.463	720	40382.0	62.930
19	967.5	51.440	280	15217.2	55.431	730	41012.9	63.241
20	1019.0	51.491	290	15771.3	55.396	740	41646.8	63.522
21	1070.5	51.542	300	16325.1	55.359	750	42283.2	63.767
22	1122.0	51.593	310	16878.5	55.321	760	42922.0	63.968
23	1173.7	51.643	320	17431.5	55.284	770	43563.0	64.265
24	1225.3	51.692	330	17984.2	55.248	780	44206.0	64.466
25	1277.0	51.741	340	18536.5	55.215	790	44852.0	64.580
26	1328.8	51.790	350	19088.5	55.186	800	45498.0	64.616
27	1380.6	51.838	360	19640.2	55.163			
28	1432.5	51.886	370	20191.8	55.145			
29	1484.4	51.934	380	20743.2	55.135			
30	1536.4	51.981	390	21294.5	55.133			
31	1588.4	52.027	400	21845.9	55.141			
32	1640.4	52.073	410	22397.4	55.160			
33	1692.5	52.119	420	22949.1	55.190			
34	1744.6	52.164	430	23501.2	55.233			
35	1796.8	52.209	440	24053.8	55.290			
36	1849.1	52.254	450	24607.1	55.361			
37	1901.3	52.298	460	25161.1	55.447			
38	1953.7	52.342	470	25716.1	55.549			
39	2006.0	52.385	480	26272.1	55.667			
40	2058.4	52.428	490	26829.5	55.804			
50	2584.8	52.835	500	27388.2	55.957			
60	3115.0	53.204	510	27948.7	56.129			
70	3648.7	53.538	520	28510.9	56.320			
80	4185.6	53.838	530	29075.1	56.529			
90	4725.4	54.107	540	29641.5	56.756			
100	5267.7	54.348	550	30210.3	57.003			
110	5812.3	54.560	560	30781.6	57.267			
120	6358.8	54.747	570	31355.7	57.549			

Table 5-1 Type J Thermocouple Reference Table

NOTE: Table above provides one degree steps from 10 to 40 °C to facilitate ambient-temperature calibration method.

JUMPERS USED		POTENTIOMETER SETTINGS							
SPAN	ZERO	ZPOT=CW SPOT=.7CW		ZPOT=CCW SPOT=.7CW		ZPOT=CCW SPOT=CCW		ZPOT=CW SPOT=CCW	
		Output		Output		Output		Output	
		4 mA	20 mA	4 mA	20 mA	4 mA	20 mA	4 mA	20 mA
NONE	NONE			-30	420	-25	760	130	760
	D	-50	365	20	470				
	C	-45	410	75	520				
	C,D	10	460	125	570				
	B	65	510	180	620				
	B,D	120	565	235	670				
	B,C	175	615	290	720				
	B,C,D	230	670	350	760				
	A	290	720						
	A,D	355	760						
E	NONE	-50	150	30	250	0	535	110	635
	D	-35	195	80	300	50	580	160	680
	C	20	240	130	350	100	625	205	720
	C,D	70	290	180	400	150	670	260	760
	B	120	340	235	455	200	715		
	B,D	175	395	290	510	250	760		
	B,C	230	450	345	565				
	B,C,D	285	505	405	620				
	A	345	565	470	675				
	A,D	410	625	530	735				
	A,C	475	680	595	760				
	A,C,D	540	740						
	A,B	610	760						
F	NONE	-50	75	55	180	-10	310	100	410
	D	-10	120	105	230	40	355	150	460
	C	45	170	155	275	90	400	200	510
	C,D	95	220	205	330	140	450	250	560
	B	145	270	260	380	190	500	300	610
	B,D	200	325	315	435	245	555	355	660
	B,C	255	380	370	495	300	605	415	710
	B,C,D	310	435	430	555	355	660	475	760
	A	370	495	490	610	415	710		
	A,D	435	555	555	670	475	760		
	A,C	495	615	620	730				
	A,C,D	565	680	685	760				
	A,B	630	740						
	A,B,D	695	760						
G	NONE	-45	35	70	140	-15	175	95	280
	D	5	80	115	190	35	220	145	325
	C	55	130	165	240	85	270	190	375
	C,D	105	180	220	290	135	320	245	430
	B	160	230	270	345	185	370	295	480
	B,D	210	285	325	400	235	420	350	535
	B,C	265	340	385	455	290	475	410	590
	B,C,D	325	395	445	515	350	535	470	645
	A	385	515	505	575	470	650	590	760
	A,D	445	515	565	635	470	650	590	760
	A,C	510	580	630	695	535	705		
	A,C,D	575	645	695	760				
	A,B	640	705						
	A,B,D	710	760						

Table 5-2 Celsius Temperature Ranges Obtained With Jumpers

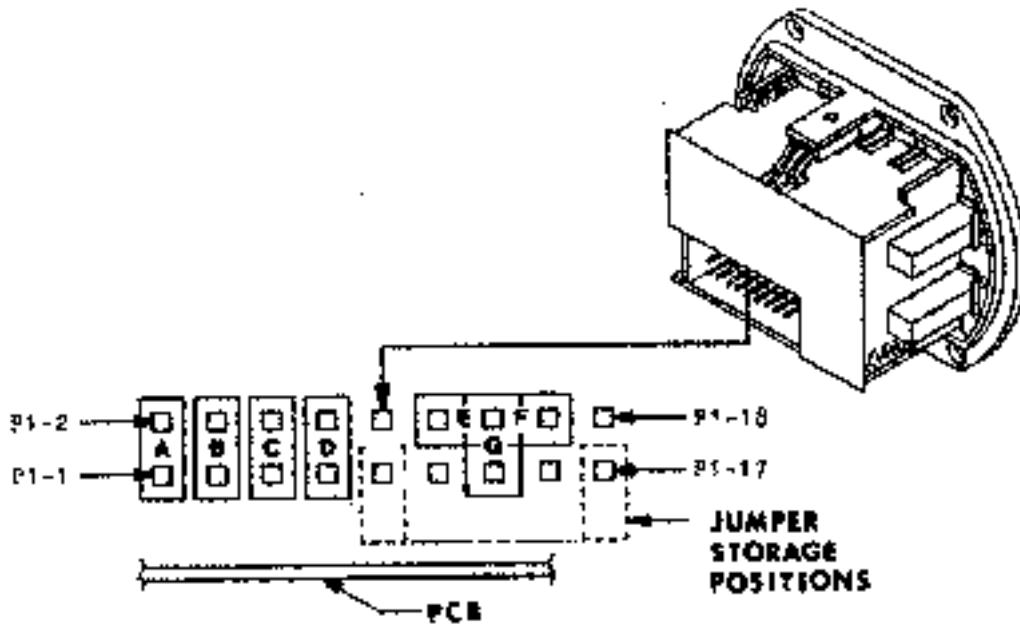

Figure 5-3 Jumper Diagram

5.4 PIN ASSIGNMENTS (Jumper Pin-forest P1)

<u>Jumper Function</u>	<u>P1 Pins Used</u>
'A' Zero	1 and 2
'B' Zero	3 and 4
'C' Zero	5 and 6
'D' Zero	7 and 8
'E' Span	12 and 14
'F' Span	14 and 16
'G' Span	13 and 14

NOTE: P1 connector pins 9, 10, 11, 15, 17 and 18 are used solely for computerized testing by the factory.

5.5 CALIBRATION FORMULA (Alternate to Using 4 mA to 20 mA Tables)

5.5.1 Calculation of ZEXTRA

When the SPAN pot is turned Clockwise it increases the output, decreasing the SPAN required for full-scale output and adding ZEXTRA, which is used to set the Zero (4 mA Temperature) jumpers.

$$ZEXTRA = (MAXSPAN - SPAN) / 4$$

5.5.2 Zero Jumper Selection (Equation alternate to Table 5-2)

From none to four jumpers may be placed on the connector to suppress the ZERO (temperature corresponding to 4 mA output). The equation is:

$$(ZERO+ZEXTRA) = 90 (8A+4B+2C+D) + 70 \times ZPOT, \text{ } ^\circ\text{C}$$

Where we put in a '1' for each jumper used (A,B,C,D) and the value of ZPOT ranges from +1.0 to 0 to -1.0 as we turn it Clockwise.

NOTE: Store the unused jumpers between the bottom connector pins and the printed-circuit board.

6.0 DRAWINGS

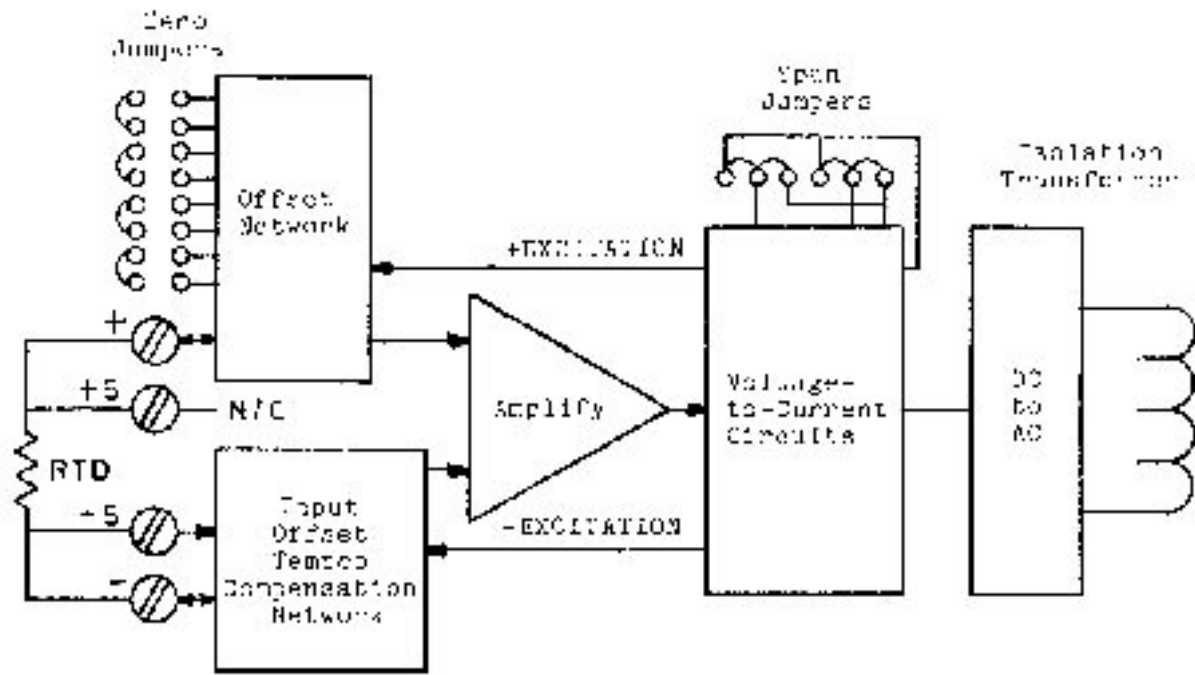

Figure 6-1 502A Preamp Block Diagram

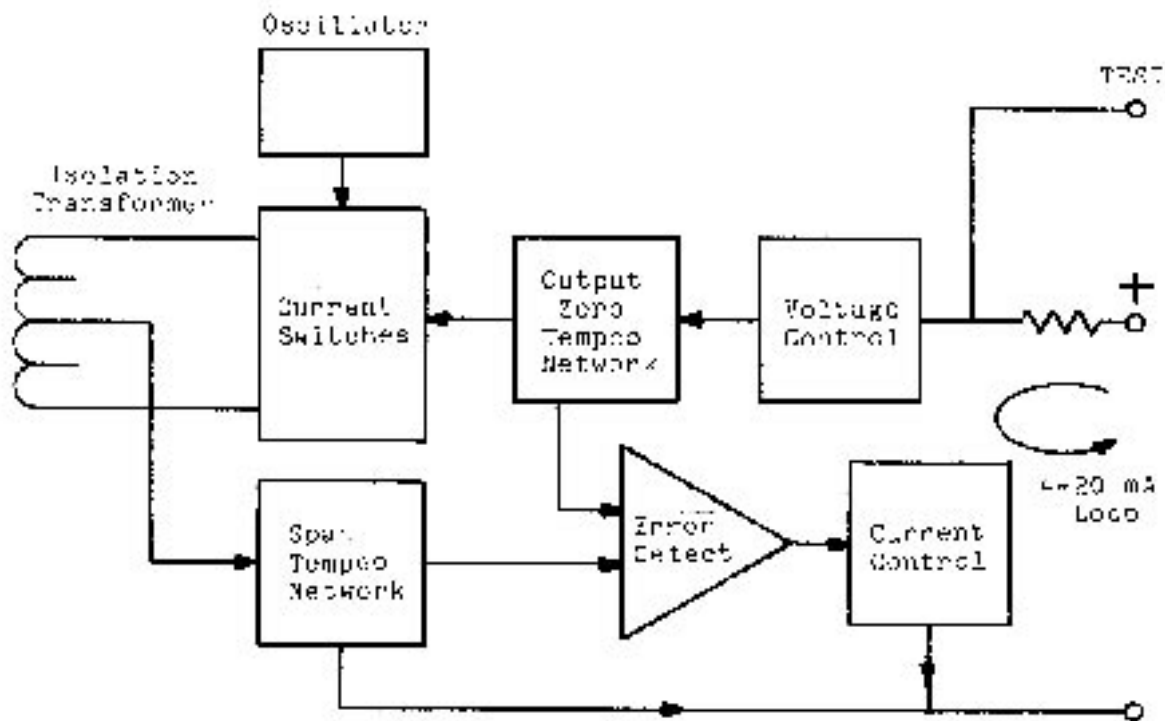

Figure 6-2 502A Postamp Block Diagram

APPENDIX A

TRANSMITTER ACCURACY SPECIFICATIONS

The complex current-transmitter circuitry necessary to amplify, isolate, protect, and offset weak input signals while consuming only small amounts of power can distort the signal in many ways. Additional accuracy limitations occur in thermocouple transmitters, which require precise cold-junction compensation and large Zero-suppression ranges in order to obtain good sensitivity and linearity for high temperatures.

Many transmitter data sheets omit key accuracy factors and/or express performance in percentage values without mentioning the full-scale value. Design limitations can be disguised by such "specsmanship"; the 502A specifications, however, are detailed in order to present the complete performance accuracy.

For a given thermocouple type, input errors are logically expressed in degrees (rather than microvolts), and output errors are readily expressed in microamperes, since output is current. Transmitter users are rarely interested in microamperes. Therefore, these output current errors are translated back to input degrees as a percentage (or ppm) of the selected Span.

Another fundamental division of errors is that of independence or dependence on Zero and Reading. Resistor aging and tempco mismatch in the Zero and Voltage Reference circuits will produce errors which increase with Zero suppression but which are independent of the amount of Reading (value above the Zero). Resistor aging and tempco mismatch in the amplifier gain (feedback) circuits will usually affect both Zero and Reading accuracy; amplifier gain tempco variations are important to just the Reading stability. A complete error specification needs a term proportional to Zero (suppression) and a term proportional to Reading.

For thermocouple transmitters, the Cold-Junction Compensation (CJC) is never perfect, even when factory-tailored over wide ambient excursions with curvilinear adjustments, as in the 502A. This error component is readily stated as a percentage of the ambient temperature excursion from the nominal temperature at which the Zero was set (assuming, as in the 502A, that the Zero potentiometer has ample resolution on all Zero and Span ranges). For transmitters with restricted turndown ratios (low Zero Suppression capability), the tempco errors may be lumped into a single error term.

In addition to these three components of tempco (ambient temperature effects), there are other possible errors, often referred to as "hysteresis," "repeatability," "drift," or "time" errors. No statistically-significant errors of these types have yet been observed for the 502A, which utilizes a solid-state, band-gap input voltage reference, matched-pair input PNP transistors, integrated-circuit current source and imbalance control, and matched-tempco bridge resistors. The 502A also provides a variable-tempco output adjustment (factory-set) which eliminates many of the errors lumped in this category for other units. The 502A specification, however, includes a 0.2°C tolerance for the calibration accuracies.

Notes: