

High-Performance Precision Rotation Stages

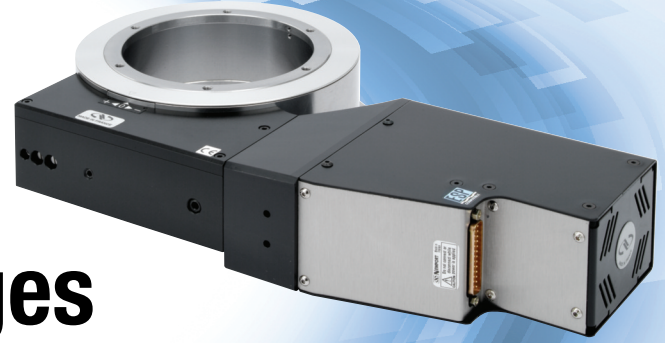

RV SERIES



The RV Series rotation stages provide high-precision angular positioning accuracy combined with high load capacity. There are five stage sizes and six drive configurations available, optimizing load capacity, torque, speed and resolution for a variety of operating conditions.

All RV stages are constructed of tool steel, with rotation accuracy ensured by ground bearing surfaces. A double row of preloaded bearings allows for high off-center loads in a reduced footprint. The single monolithic design offers improved stiffness without compromising dynamic performance. The largest RV stage can bear up to 6500 N or rotate up to 80 °/s, while maintaining less than 4 um eccentricity.

Precise rotation is ensured by a precision ground and hardened worm gear. A rotary encoder mounted on the worm gear shaft provides 0.001° position feedback resolution (0.00025° resolution with RVS80CC) on the standard configurations. For more demanding applications, the HAT and HAHLT options are available on the RV120 to RV350 models. These stages are equipped with a direct reading optical encoder attached to the moving platen for superior resolution and accuracy.

The selection of the drive configuration should be based on the precision and speed requirements relative to the inertia of the payload.

Motor Drive Versions

Stepper motor-driven stages are available in full step BPE and mini-step PP or BPP versions. The mini-step drive version enables high angular speed motions up to 20 °/s. The larger models, RV120BPP to RV350BPP, feature a worm mounted rotary encoder for improved accuracy and repeatability. The encoder also provides a method for detecting motor stalling, an important feature for applications with high acceleration ramps and high torques or payload inertias.

- Precision 80–350 mm diameter rotation stages
- Monolithic design ensures high structural stiffness
- Ideal for high-load application
- High-accuracy versions with direct reading encoder and better than 0.0001° (0.36 arcsec) resolution

DESIGN DETAILS

Base Material	Stainless Steel	
Bearings	Double row ball bearings	
Drive Mechanism	Ground worm gear with self compensating preload	
Worm Gear Ratio	RVS80: 1:180 RV120 to RV350: 1:90	
Feedback	RVS80CC: Worm mounted rotary encoder, 8,000 pts/rev, Index pulse RVS80PP: None. One full-step equals 0.01° RV120 to RV350: <ul style="list-style-type: none"> • except for HAT and HAHLT versions: Worm mounted rotary encoder, 4,000 pts/rev, Index pulse • HAT and HAHLT versions: Direct reading optical encoder on the rotating platen, 20 mm signal period 	
Limit Switches	Optical, at ±170°, can be disabled for continuous rotation (except HAT, HAHLT and HAHLT versions)	
Origin	Optical	
Cable Length	3 m cable included	
Vacuum Compatibility	Vacuum compatible versions are available up to 10 ⁻⁶ hPa using full-step motor, in this case, max. speed and load capacity have to be divided by two	
Weight [lb (kg)]	RVS80: 4.0 (1.8) RV120: 14.3 (6.5) RV160: 19.8 (9) RV240: 35.3 (16) RV350: 57.5 (27)	RV120HAT: 17.6 (8) RV160HAT: 24.2 (11) RV240HAT: 41.9 (19) RV350HAT: 72.8 (33)

RV SERIES

The RVS80PP does not use an encoder. Instead, position is attained by the number of commanded steps and micro-steps. The high output torque of the stepper motor, combined with extensive performance tests, ensures position accuracy as long as the recommended load, torque and payload inertia are not exceeded. The RVS80PP provides very high motion sensitivity with good linearity between commanded micro-steps and the actual motion of the stage at a very reasonable price. The full-step PE version is equipped with a reduction gear providing higher torque. This version is only available on the models RV120 to RV350 and is recommended for high inertia payloads and vacuum applications.

DC motor-driven stages are available in high speed (CC and HAT) and high torque (CCHL and HAHLT) versions. The CC and HAT versions enable speeds up to 80 °/s. The HAT features a high-resolution direct reading encoder and tachometer for superior repeatability, position stability and speed regulation. The CCHL and HAHLT versions are equipped with a reduction gear providing higher torque and payload inertia capacity. The HAHLT features a high-resolution direct reading encoder and tachometer for superior repeatability, position stability and speed regulation.

SPECIFICATIONS



RVS80CC

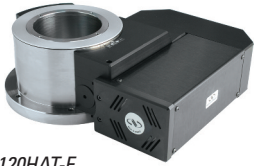

RV120HAT-F

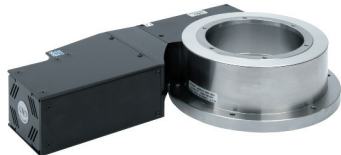

RV160BPP

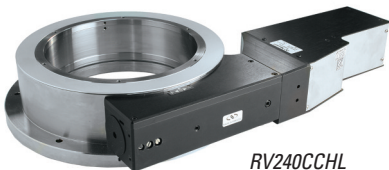

RV240CCHL



RV350HAHLT

Travel Range (°)	360 continuous	With disabled limits, except RV-HAT & HAHLT versions
	±170	RV-HAT & HAHLT versions
Minimum Incremental Motion (mdeg)	1.0	Except RVS80PP and RV-HAT & HAHLT versions
	0.75	RV-HAT versions
	0.2	RVS80PP and RV-HAHLT versions
Uni-directional Repeatability ⁽¹⁾ (mdeg)	±0.5 (±1.0)	RVS80PP
	Typical (Guaranteed)	±0.36 (±1.0) RVS80CC
Bi-directional Repeatability ⁽¹⁾ (mdeg)	±0.35 (±1.0)	Except RV-HAT & HAHLT versions
	±0.09 (±0.1)	RV120HAT & HAHLT
	±0.08 (±0.1)	RV160HAT & HAHLT
	±0.07 (±0.1)	RV240 & RV350HAT & HAHLT
	Typical (Guaranteed)	±2.8 (±3.5) RVS80PP ±1.2 (±1.5) RVS80CC
Absolute Accuracy ⁽¹⁾ (mdeg)	±0.7 (±2.0)	RV120 & RV160 Except HAT & HAHLT
	±0.6 (±2.0)	RV240 & RV350 Except HAT & HAHLT
	±0.45 (±0.6)	RV160HAT & HAHLT
	±0.4 (±0.6)	RV120 RV240 & RV350HAT & HAHLT
	Typical (Guaranteed)	±7.0 (±10) RVS80 ±4.0 (±7.5) RV120 Except HAT & HAHLT ±4.0 (±5.0) RV160 Except HAT & HAHLT ±3.5 (±5.0) RV240 & RV350 Except HAT & HAHLT ±2.0 (±2.5) RV-HAT & HAHLT versions
Origin Repeatability (mdeg)	±10	RVS80PP
	±0.5	Except RV-HAT & HAHLT versions
	±0.25	RVS80CC
Maximum Speed (°/s)	±0.1	RV-HAT & HAHLT versions
	80	RV-CC & HAT versions
	40	RVS80CC
	20	RVS80PP & RV-BPP versions
	16	RV-CCHL, HAHL & HAHLT versions
Wobble ⁽¹⁾⁽²⁾ (µrad)	2	RV-BPE versions
	Typical (Guaranteed)	±8.0 (±20) RVS80 ±5.0 (±10) RV120 & RV160 ±4.0 (±8.0) RV 240 & RV350
	Eccentricity, Guaranteed ⁽¹⁾ (µm)	±0.5 (±2.0)
±0.6 (±2.0)		RV120
Typical (Guaranteed)		±0.8 (±2.0) RV160 & RV240 ±1.4 (±2.0) RV350

¹⁾ For the definition of Typical and Guaranteed specifications see "Motion Basics Terminology & Standards" Tutorial at www.newport.com

²⁾ To obtain arcsec units, divide µrad value by 4.8.

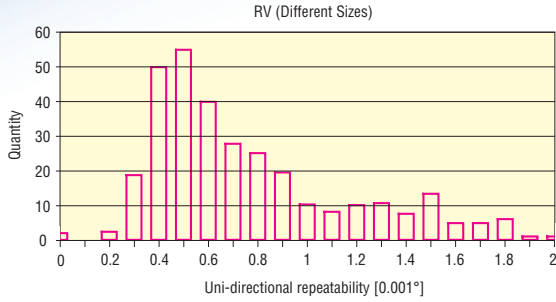

Uni-directional repeatability plot for RV Series stages. The typical (mean) uni-directional repeatability is 0.001°. The guaranteed value is 0.002°.

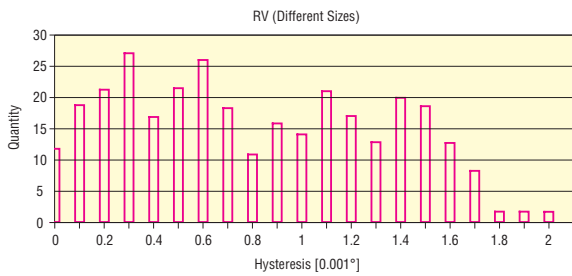

Reversal value (Hysteresis) plot for RV Series stages. The typical (mean) reversal value is 0.001°. The guaranteed value is 0.002°.

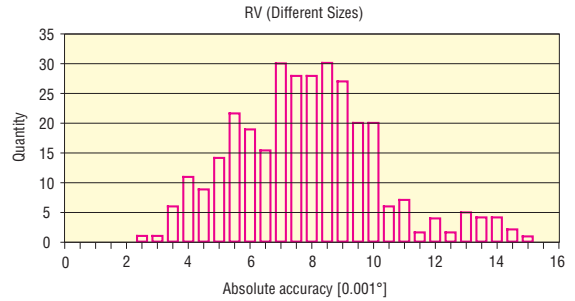

On-axis accuracy plot for RV Series stages. The typical (mean) on-axis accuracy is 0.001°. The guaranteed value is 0.002°.

LOAD CHARACTERISTICS

	RV580	RV120	RV160	RV240	RV350
Cz, Normal centered load capacity (N)	900	1800	2700	4000	6500
a, construction parameter (mm)	30	40	50	70	100
b ⁽¹⁾ , (mm) except HAT, HAHL & HAHLT	39	53	57	59	73
for HAT, HAHL & HAHLT		71	75	77	91
kα, radial compliance (μrad/Nm)	3.5	1.5	0.6	0.3	0.1
QH, Off-center load, vertical rotation axis	$Q_H \leq C_z \div (1 + D/a)$				
QV, Off-center load, horizontal rotation axis	$Q_V \leq C_z/2 \div (1 + D/a)$				

¹⁾ Construction parameter: Distance between the top surface of the RV stage and the bearing center.

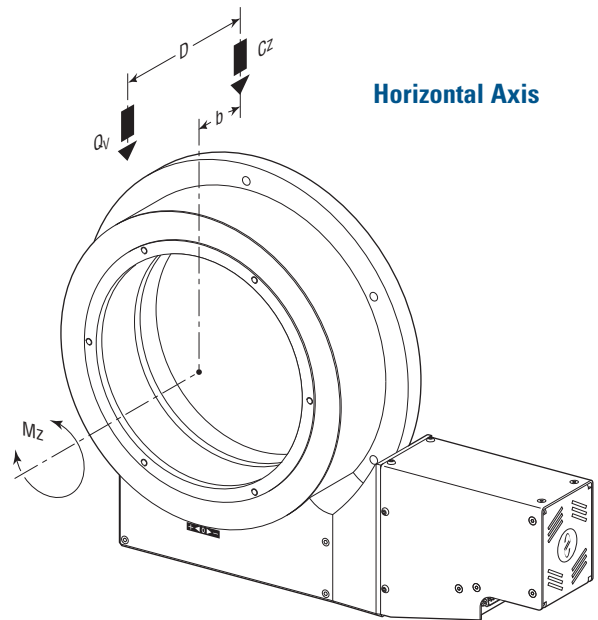

Vertical Axis

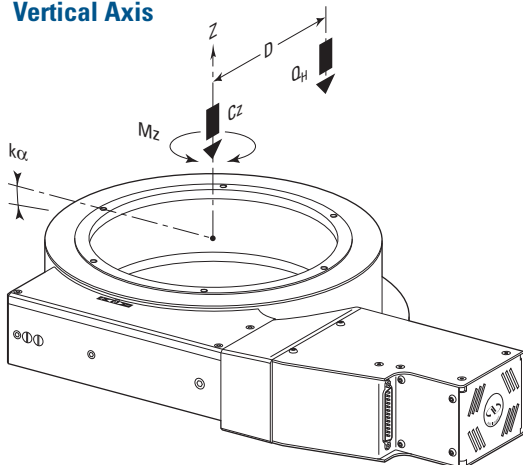

Example: Q_V at a distance D of 100 mm, for RV160 rotation stage.

$$Q_V = \frac{2700}{[2 \times (1 + 100/50)]} = 450 \text{ N}$$

In this example, the load Q_V is placed at 43 mm (100 - 57) from the mounting plane of the stage.

Example: Q_H at a distance D of 100 mm, for RV160 rotation stage.

$$Q_H = \frac{2700}{(1 + 100/50)} = 900 \text{ N}$$

RV SERIES

TORQUE AND PAYLOAD INERTIA

This table lists the maximum torque and the maximum payload inertia for all RV rotation stages. The maximum payload inertia equals the maximum kinetic energy that the rotation stage can absorb in the event of a sudden stop at the maximum speed. Likewise, this is the maximum inertia to accelerate from stop to the maximum stage speed in 250 ms. Some RV stages can handle higher payload inertias at reduced speed. For detailed information, please contact a Newport Applications Engineer.

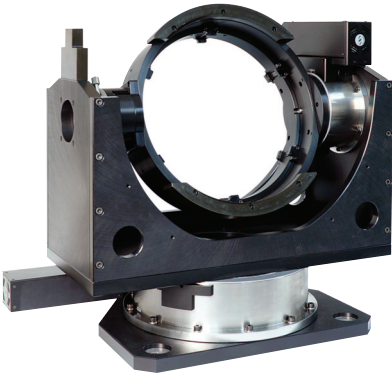

This Azimuth/Elevation gimbal system positions a 350 mm dia. mirror that can be used for laser based qualification and characterization of precision optical sensors, LIDAR analysis, or target tracking.

Model	Max. Torque Mz (Nm)	Max. Inertia Iz (kg.m ²)	Max. Speed (°/s)
RVS80PP	2	0.5	20
RVS80CC	2	0.1	40
RV120BPP	15	1	20
RV120BPE	20	70	2
RV120CC	10	0.2	80
RV120CCHL	15	7	16
RV120HAT	4	0.9	80
RV120HAHLT	6	7	16
RV160BPP	20	3	20
RV160BPE	35	100	2
RV160CC	11	0.7	80
RV160CCHL	20	24	16
RV160HAT	6	1	80
RV160HAHLT	8	8	16
RV240BPP	22	4	20
RV240BPE	60	150	2
RV240CC	13	1.5	80
RV240CCHL	30	38	16
RV240HAT	7	1.1	80
RV240HAHLT	10	10	16
RV350BPP	25	4	20
RV350BPE	80	220	2
RV350CC	14	1.8	80
RV350CCHL	30	56	16
RV350HAT	7	1.2	80
RV350HAHLT	10	10	16

RECOMMENDED CONTROLLERS/DRIVERS

Model	Description
XPS-D	1- to 8-axis universal high-performance motion controller/driver
XPS-DRV11	Universal digital driver card for stepper, DC and direct motors
XPS-RL	1- to 4-axis universal high-performance motion controller/driver
XPS-DRV01	PWM drive module for DC brush and stepper motors, 3 A/43 V max.
XPS-DRV03	High performance PWM drive module for DC motors, 5 A/43 V max.
ESP301	1- to 3-axis motion controller/driver
SMC100CC	Single-axis DC motor controller/driver
SMC100PP	Single-axis stepper motor controller/driver

COMPATIBLE CONTROLLERS/DRIVERS

Family	Max. Power Consumption (W)	XPS ⁽¹⁾ Driver Module	Compatibility		
			ESP301 ⁽¹⁾	SMC100CC ⁽¹⁾	SMC100PP ⁽¹⁾
RV120CC to RV350CC	130	XPS-DRV03			
RV120CCHL	40	XPS-DRV03	✓		
RV160CCHL to RV350CCHL	130	XPS-DRV03			
RV120HAT to RV350HAT	170	XPS-DRV03			
RV120HAHLT to RV350HAHLT	170	XPS-DRV03			
RV120PE to RV350PE	60	XPS-DRV01	✓		
RV120BPP to RV350BPP	60	XPS-DRV01	✓		
RVS80CC	40	XPS-DRV01	✓	✓	
RVS80PP	20	XPS-DRV01	✓		✓ ⁽²⁾

¹⁾ Enhanced System Performance (ESP) Controller.

²⁾ Compatible, but MIM is 1/20 th of a full step.

DIMENSIONS

RVS80 Models

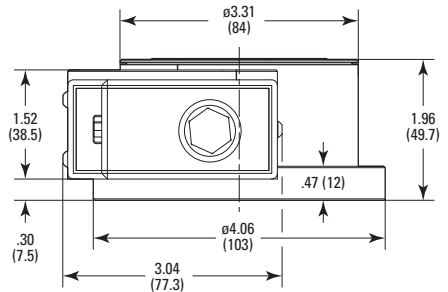
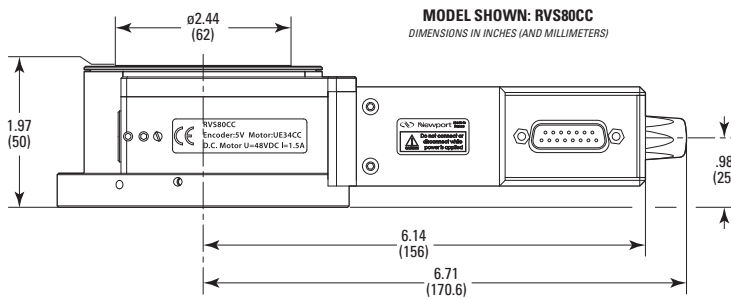
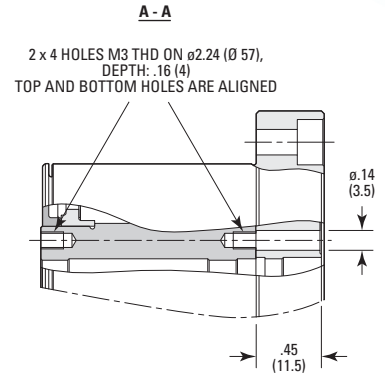
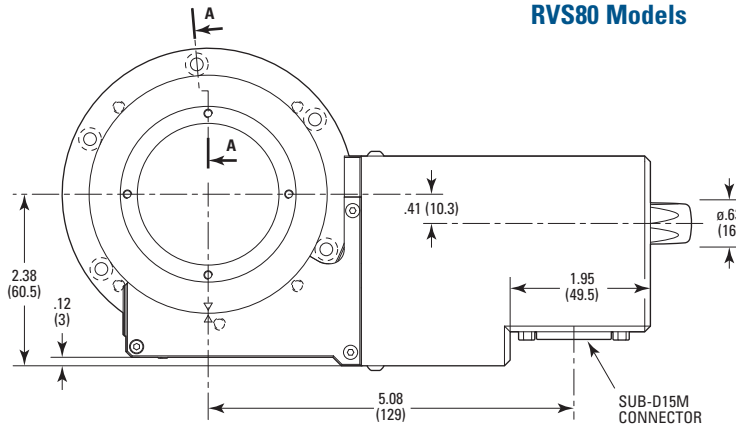

BOTTOM VIEW OF THE RVS80PP

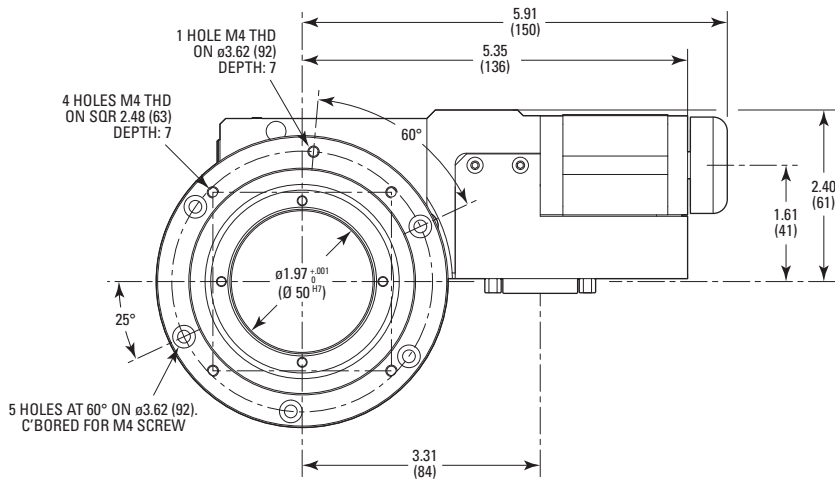

RVS80PP and RVS80CC rotations stages.

RV SERIES

RV120 to RV350 BPP, BPE, CC & CCHL Models

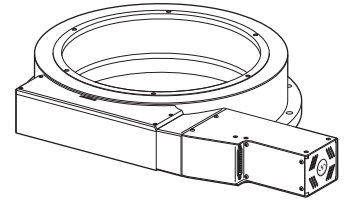
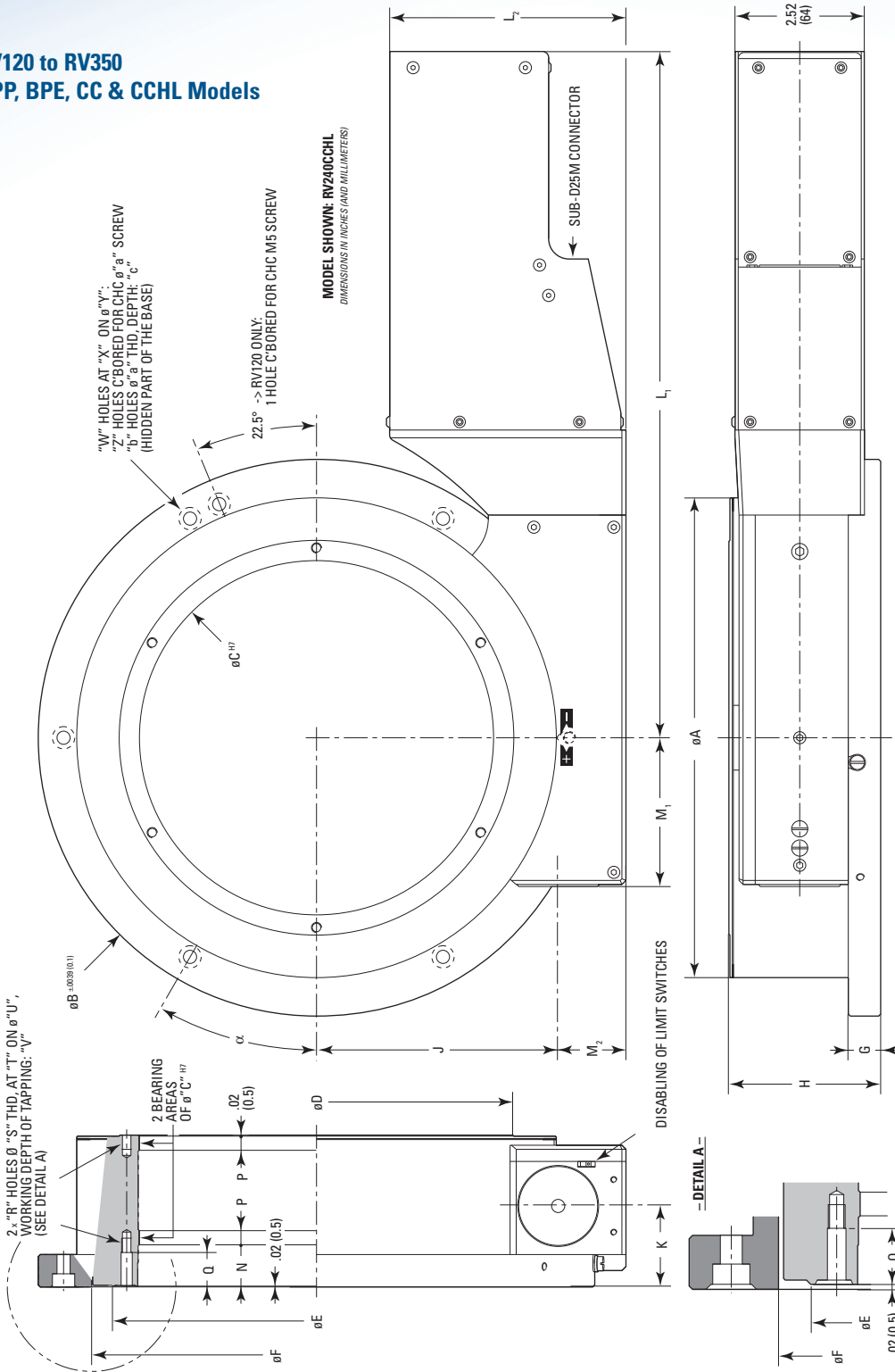

ROTATION STAGE, DIRECT MOTOR

MODEL	L_1				M_1	L_2	M_2
	BPP	BPE	CC	CCHL			
RV120	9.90 (251.5)	9.90 (251.5)	9.90 (251.5)	11.87 (301.5)	1.79 (45.5)		
RV160	10.39 (264)	12.36 (314)	10.39 (264)	12.36 (314)	2.13 (54)	4.61 (117)	1.32 (33.5)
RV240	11.38 (289)	13.35 (339)	11.38 (289)	13.35 (339)	2.89 (73.5)		
RV350	12.40 (315)	14.37 (365)	12.40 (315)	14.37 (365)	4.13 (105)		

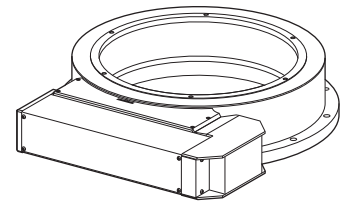

ROTATION STAGE, FOLDED MOTOR

MODEL	L_1	M_1	L_2	M_2
RV160	6.61 (168)	2.48 (63)	6.32 (160.5)	4.35 (110.5)
RV240	7.60 (193)	3.25 (82.5)		
RV350	8.62 (219)	4.49 (114)		

MODEL	A	B	C	D	E	F	G	H	J	K	N	P	Q
RV120	4.96 (126)	6.10 (155)	3.07 (78)	3.70 (94)	3.84 (97.5)	4.55 (115.5)	.55 (14)	2.68 (68)	2.48 (63)	1.34 (34)	.75 (19)	.16 (4)	.59 (15)
RV160	6.42 (163)	7.56 (192)	4.33 (110)	5.12 (130)	5.22 (132.5)	5.98 (152)	.55 (14)	2.80 (71)	3.21 (81.5)	1.42 (36)	.73 (18.5)	.20 (5)	.57 (14.5)
RV240	9.33 (237)	10.83 (275)	6.89 (175)	7.68 (195)	7.93 (201.5)	8.74 (222)	.63 (16)	2.95 (75)	4.70 (119.5)	1.58 (40)	.80 (20.3)	.28 (7)	.65 (16.6)
RV350	14.02 (356)	15.55 (395)	11.02 (280)	11.97 (304)	12.32 (313)	13.05 (331.5)	.69 (17.5)	3.54 (90)	7.05 (179)	1.97 (50)	.84 (21.3)	.31 (8)	.68 (17.3)

MODEL	R	S	T	U	V	W	X	Y	Z	a	b	c	α
RV120	4	M4	90°	3.44 (87.5)	.24 (6)	6	60°	5.39 (137)	5	M5	1	7	17.5°
RV160	6	M5	60°	4.72 (120)	.28 (7)	6	60°	6.85 (174)	5	M5	1	7	25°
RV240	6	M5	60°	7.38 (187.5)	.28 (7)	6	60°	9.84 (250)	5	M6	1	10	30°
RV350	6	M6	60°	11.61 (295)	.28 (7)	12	30°	14.65 (372)	10	M8	2	12	10°

RV120 to RV350 HAT, HAHL & HAHLT Models

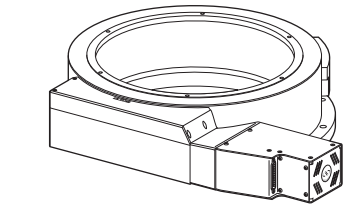
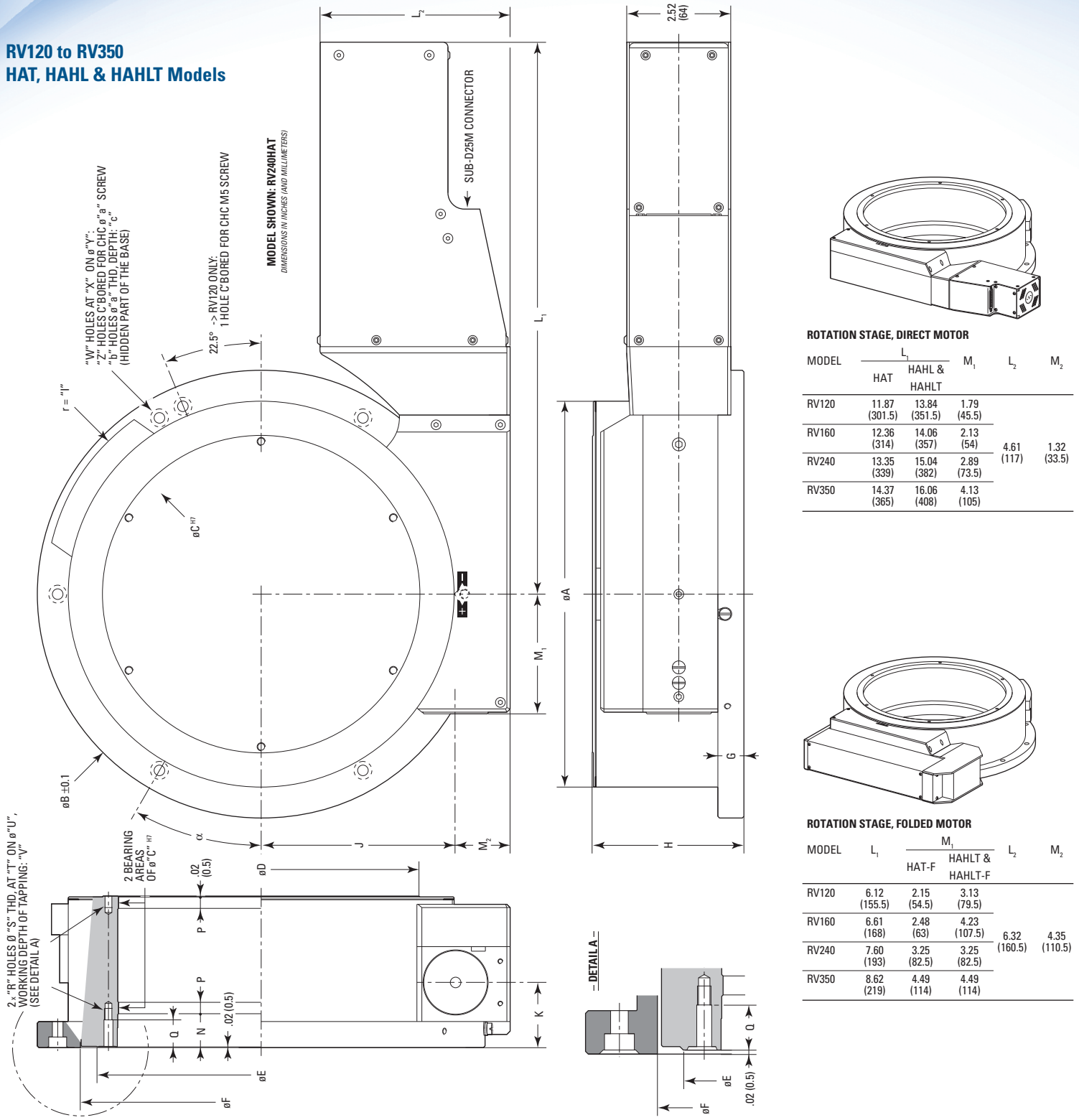

ROTATION STAGE, DIRECT MOTOR

MODEL	L ₁		M ₁	L ₂	M ₂
	HAT	HAHL & HAHLT			
RV120	11.87 (301.5)	13.84 (351.5)	1.79 (45.5)		
RV160	12.36 (314)	14.06 (357)	2.13 (54)	4.61 (117)	1.32 (33.5)
RV240	13.35 (339)	15.04 (382)	2.89 (73.5)		
RV350	14.37 (365)	16.06 (408)	4.13 (105)		

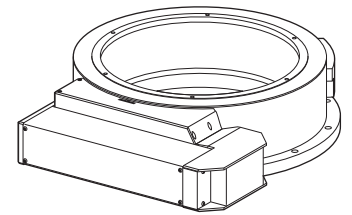

ROTATION STAGE, FOLDED MOTOR

MODEL	L ₁	M ₁		L ₂	M ₂
		HAT-F	HAHLT & HAHLT-F		
RV120	6.12 (155.5)	2.15 (54.5)	3.13 (79.5)		
RV160	6.61 (168)	2.48 (63)	4.23 (107.5)	6.32 (160.5)	4.35 (110.5)
RV240	7.60 (193)	3.25 (82.5)	3.25 (82.5)		
RV350	8.62 (219)	4.49 (114)	4.49 (114)		

MODEL	A	B	C	D	E	F	G	H	I	J	K	N	P	Q
RV120	4.96 (126)	6.10 (155)	3.07 (78)	3.70 (94)	3.84 (97.5)	4.55 (115.5)	.55 (14)	3.39 (86)	3.15 (80)	2.48 (63)	1.34 (34)	.75 (19)	.16 (4)	.59 (15)
RV160	6.42 (163)	7.56 (192)	4.33 (110)	5.12 (130)	5.22 (132.5)	5.98 (152)	.55 (14)	3.50 (89)	3.86 (98)	3.21 (81.5)	1.42 (36)	.73 (18.5)	.20 (5)	.57 (14.5)
RV240	9.33 (237)	10.83 (275)	6.89 (175)	7.68 (195)	7.93 (201.5)	8.74 (222)	.63 (16)	3.66 (93)	5.22 (132.5)	4.70 (119.5)	1.58 (40)	.80 (20.3)	.28 (7)	.65 (16.6)
RV350	14.02 (356)	15.55 (395)	11.02 (280)	11.97 (304)	12.32 (313)	13.05 (331.5)	.69 (17.5)	4.25 (108)	7.44 (189)	7.05 (179)	1.97 (50)	.84 (21.3)	.31 (8)	.68 (17.3)

MODEL	R	S	T	U	V	W	X	Y	Z	a	b	c	α
RV120	4	M4	90°	3.44 (87.5)	.24 (6)	6	60°	5.39 (137)	5	M5	1	7	17.5°
RV160	6	M5	60°	4.72 (120)	.28 (7)	6	60°	6.85 (174)	5	M5	1	7	25°
RV240	6	M5	60°	7.38 (187.5)	.28 (7)	6	60°	9.84 (250)	5	M6	1	10	30°
RV350	6	M6	60°	11.61 (295)	.28 (7)	12	30°	14.65 (372)	10	M8	2	12	10°

ORDERING INFORMATION

Direct Motor Versions		Models			
Mini-step	RVS80PP	RV120BPP	RV160BPP	RV240BPP	RV350BPP
Full-step	–	RV120BPE	RV160BPE	RV240BPE	RV350BPE
Full-step & vacuum preparation	–	RV120BPEV6	RV160BPEV6	RV240BPEV6	RV350BPEV6
Vacuum compatible to 10 ⁻⁶ hPa. In this case, max. speed and load capacity have to be divided by two.					
DC	RVS80CC	RV120CC	RV160CC	RV240CC	RV350CC
HAT: DC & integral optical encoder	–	RV120HAT	RV160HAT	RV240HAT	RV350HAT
CCHL: DC & gear reduction	–	RV120CCHL	RV160CCHL	RV240CCHL	RV350CCHL
HAHLT: CCHL version & integral optical encoder	–	RV120HAHLT	RV160HAHLT	RV240HAHLT	RV350HAHLT
Folded Motor Versions		Except RVS80, add -F for folded motor versions.			

Note: For higher capacity rotary stages, please call an Applications Engineer.

ACCESSORIES

Newport's EQ120 and EQ180 brackets (to order separately) are ideal for mounting our ILS or IMS Series of linear stages and RV80 to RV160 rotation stages for stable and stiff multi-axis positioning systems.



EQ180 bracket on an (M-)IMS stage, with an RV160 in vertical configuration.

Model	Description
EQ120	Right-Angle Bracket for ILS and RV
EQ180	Right-Angle Bracket for IMS, RV120 and RV160

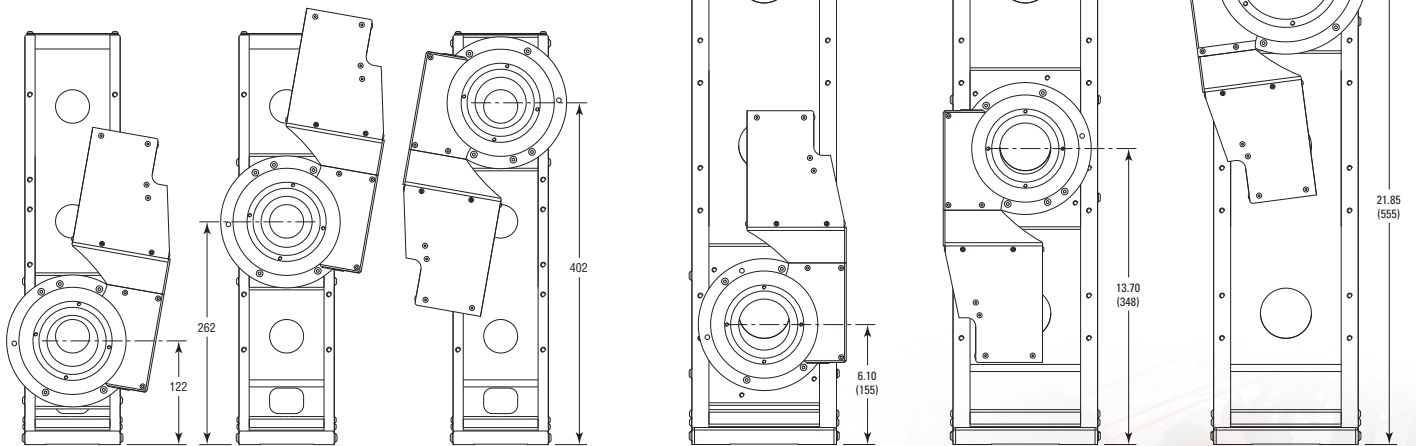

Newport Corporation, Global Headquarters
1791 Deere Avenue, Irvine, CA 92606, USA

PHONE: 1-800-222-6440 1-949-863-3144 FAX: 1-949-253-1680 EMAIL: sales@newport.com
Complete listings for all global office locations are available online at www.newport.com/contact

www.newport.com